

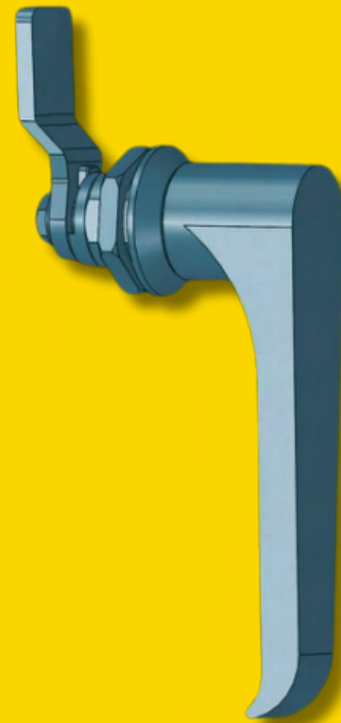



# STAINLESS STEEL INDUSTRIAL LOCKS

**HOT**  
HARDWARE ON TIME



 [www.hardwareontime.com](http://www.hardwareontime.com)  
 [Info@hardwareontime.com](mailto:Info@hardwareontime.com)  
 +861 5001 790 862



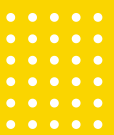

## ***OUR PRODUCTS***

- ✓ **SWINGHANDLES**
- ✓ **HANDLES**
- ✓ **HINGES**
- ✓ **QUARTER TURN**
- ✓ **SECURITY  
QUARTER TURN**
- ✓ **FITTINGS**
- ✓ **KEYS**
- ✓ **COMPRESSION  
LATCH**
- ✓ **CAM**

## **STAINLESS STEEL INDUSTRIAL LOCKS**



 [www.hardwareontime.com](http://www.hardwareontime.com)

 [Info@hardwareontime.com](mailto:Info@hardwareontime.com)

 +861 5001 790 862



# SWINGHANDLES

## SWINGHANDLE HT-316

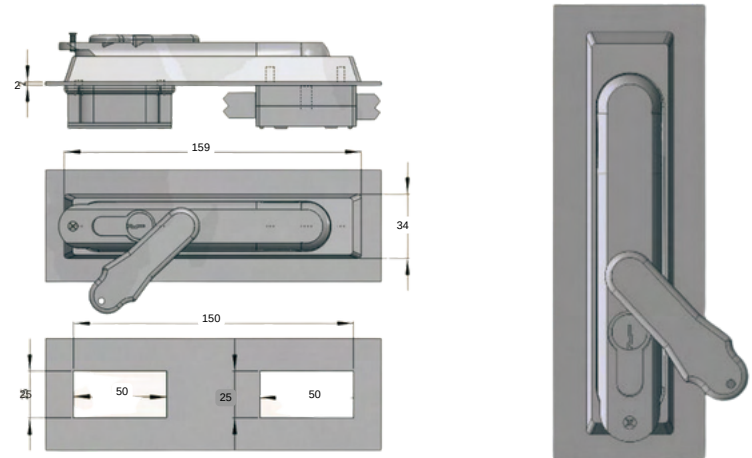

ZINC DIE-CAST CYLINDER  
1810-HT-1.1

BRASS CYLINDER  
1810-HT-1.2

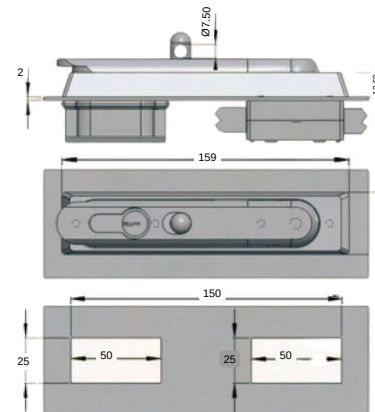

ZINC DIE-CAST CYLINDER  
1810-HT-1.3

BRASS CYLINDER  
1810-HT-1.4

# SWINGHANDLE HT-316



# SWINGHANDLE HT-316

# SWINGHANDLES

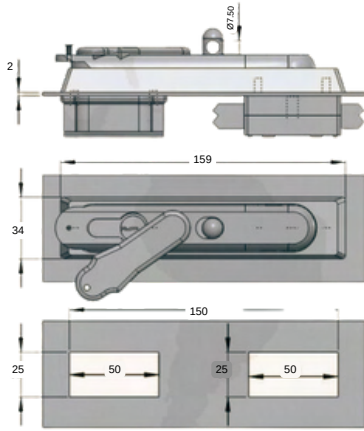

ZINC DIE-CAST CYLINDER  
1810-HT-2.1

BRASS CYLINDER  
1810-HT-2.2

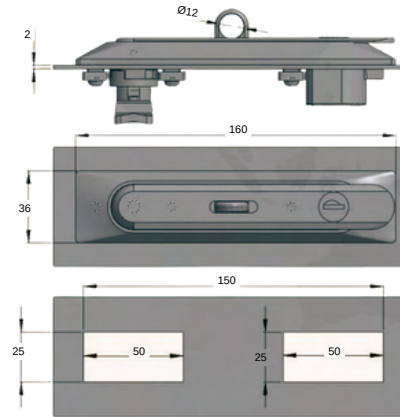

ZINC DIE-CAST CYLINDER  
1810-HT-4.1

BRASS CYLINDER  
1810-HT-4.2

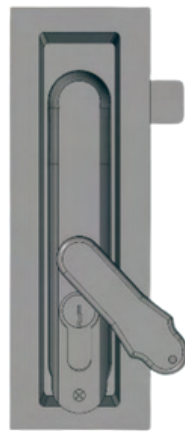
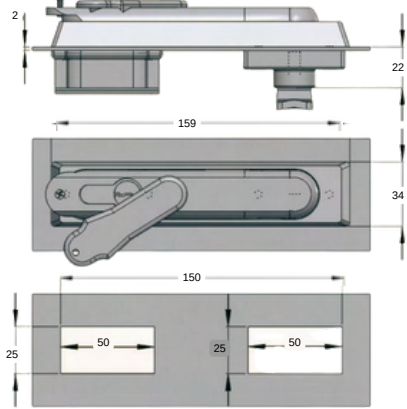

ZINC DIE-CAST CYLINDER  
1810-HT-3.1

BRASS CYLINDER  
1810-HT-3.2

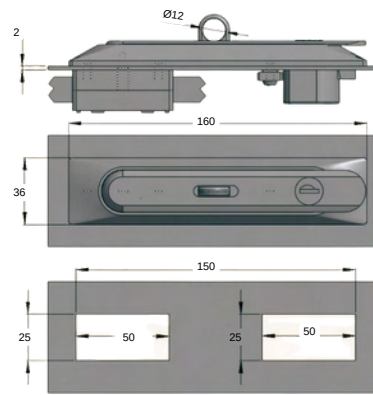

ZINC DIE-CAST CYLINDER  
1810-HT-5.1

BRASS CYLINDER  
1810-HT-5.2



# SWINGHANDLE HT-316



# SWINGHANDLE HT-316

# SWINGHANDLES

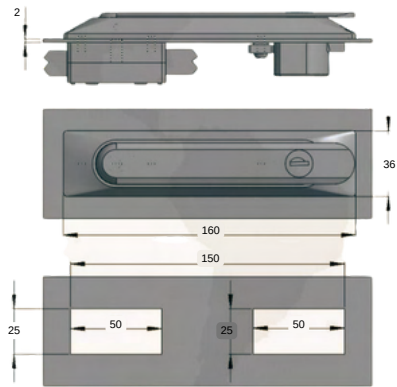

ZINC DIE-CAST CYLINDER  
1810-HT-6.1

BRASS CYLINDER  
1810-HT-6.2

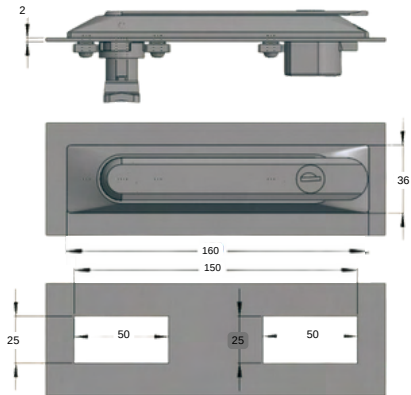

ZINC DIE-CAST CYLINDER  
1810-HT-7.1

BRASS CYLINDER  
1810-HT-7.2

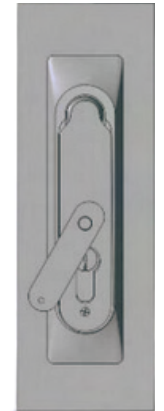
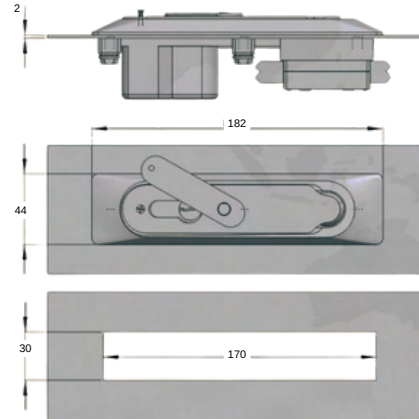

ZINC DIE-CAST CYLINDER  
1810-HT-8.1

BRASS CYLINDER  
1810-HT-8.2

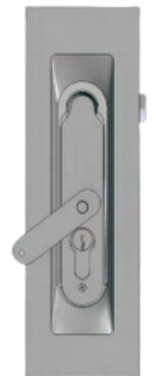
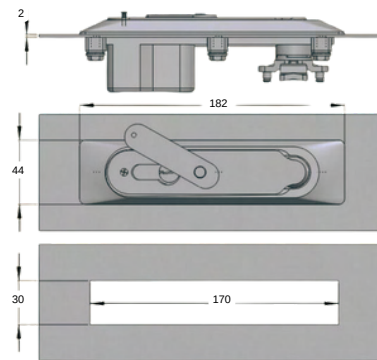

ZINC DIE-CAST CYLINDER  
1810-HT-9.1

BRASS CYLINDER  
1810-HT-9.2

**SWINGHANDLE HT-316**

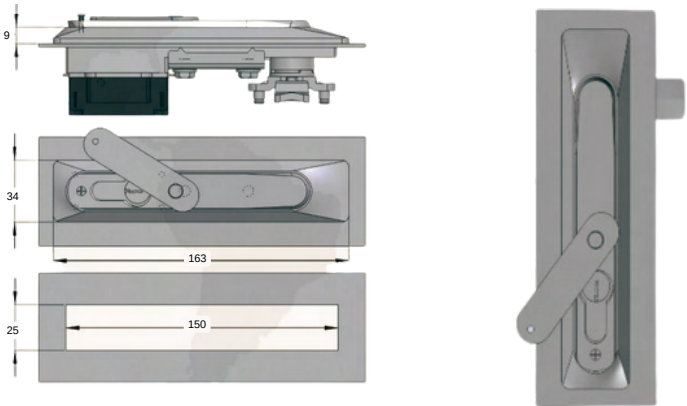

ZINC DIE-CAST CYLINDER  
1810-HT-10.1

BRASS CYLINDER  
1810-HT-10.2

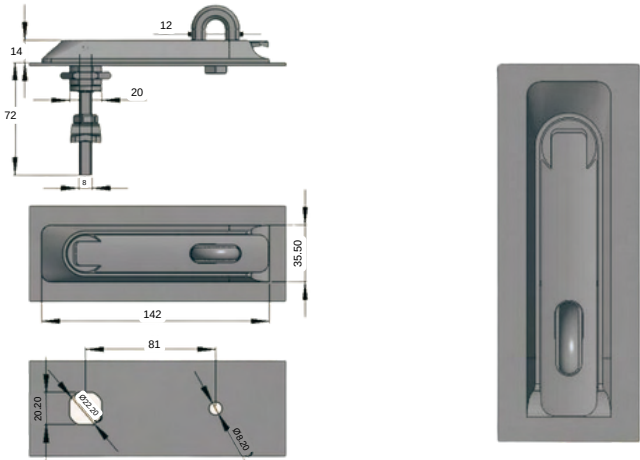

FOR PADLOCKING  
1810-HT-11.1

**SWINGHANDLES**



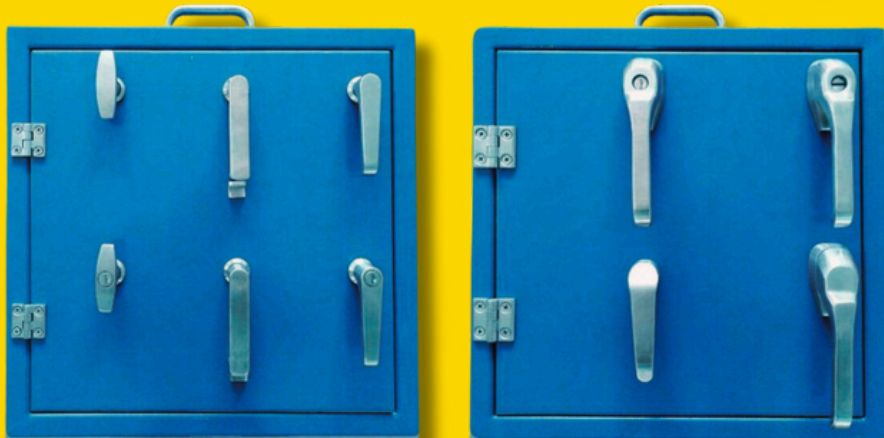

## HANDLES

### L-HANDLE HT-316

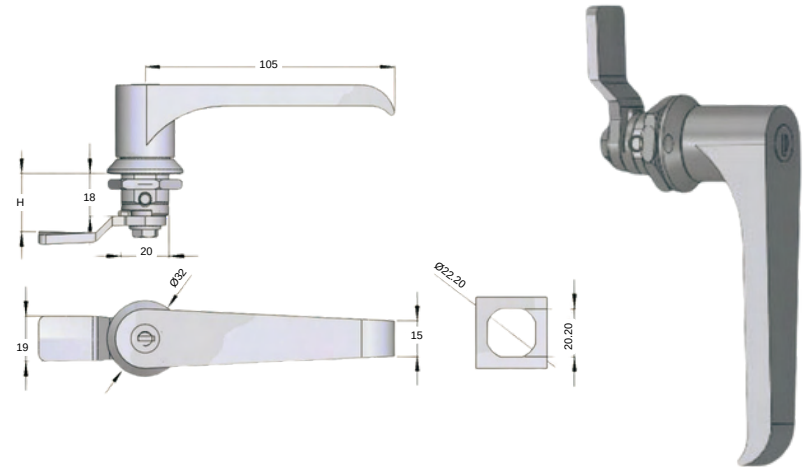

ZINC DIE-CAST CYLINDER	STAINLESS STEEL CYLINDER
2310-HT-1.1	2310-HT-1.2

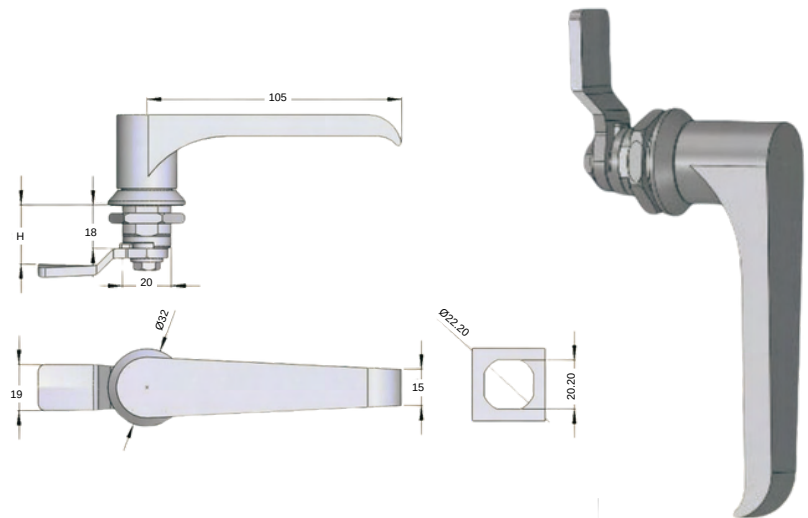

NON LOCKING HANDLE  
2310-HT-1.3

# T-HANDLE HT-316



# WING KNOB HT-316

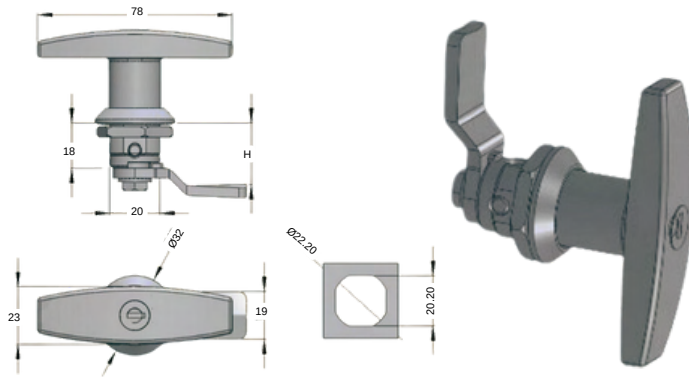

ZINC DIE-CAST CYLINDER | STAINLESS STEEL CYLINDER  
2310-HT-2.1 | 2310-HT-2.2

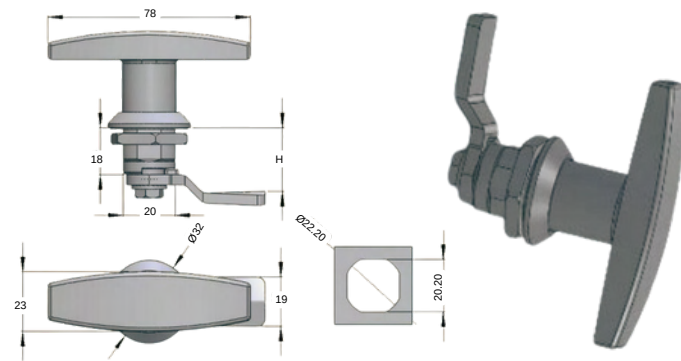

NON LOCKING HANDLE  
2310-HT-2.3

# HANDLES

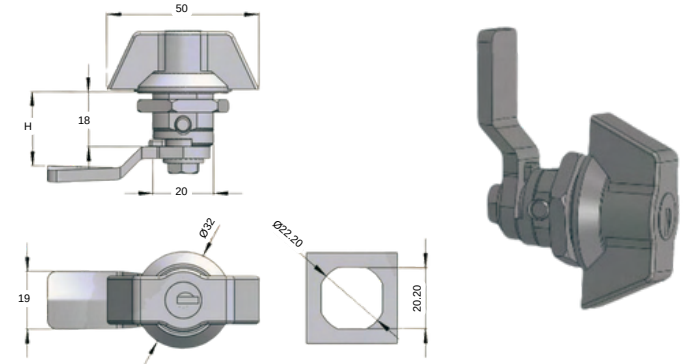

ZINC DIE-CAST CYLINDER | STAINLESS STEEL CYLINDER  
2310-HT-3.1 | 2310-HT-3.2

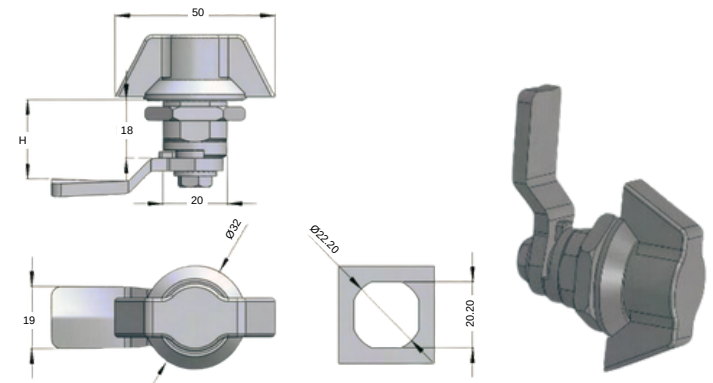

NON LOCKING HANDLE  
2310-HT-3.3

**HEAVY DUTY HANDLE  
HT-316**



**HEAVY DUTY HANDLE  
HT-316**

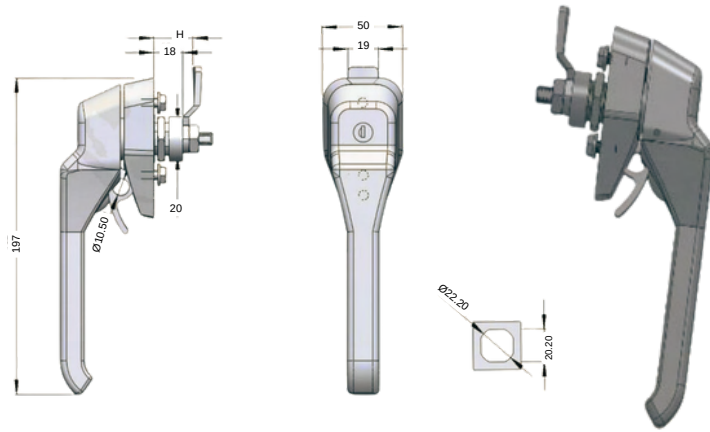

**ZINC DIE-CAST CYLINDER**  
2310-HT-4.1

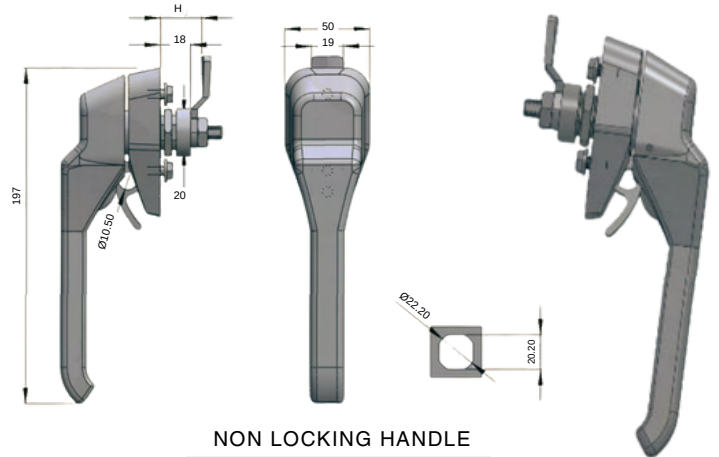

**NON LOCKING HANDLE**  
2310-HT-4.3

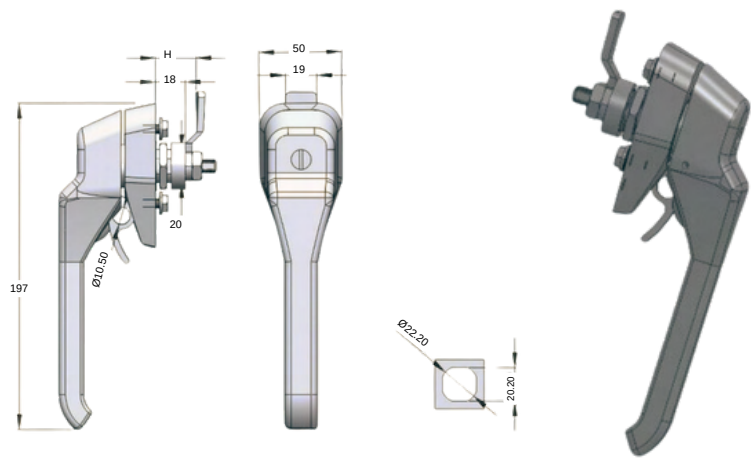

**STAINLESS STEEL CYLINDER**  
2310-HT-4.2

**HANDLES**

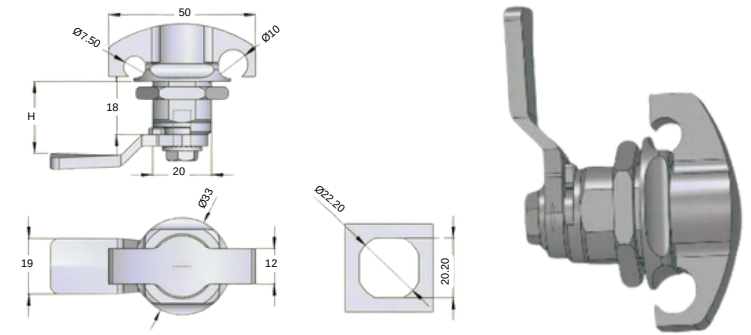

**NON LOCKING HANDLE**  
2310-HT-5.1

**L-HANDLE FOR  
PADLOCK HT-316**



**L-HANDLE FOR  
PADLOCK HT-316**

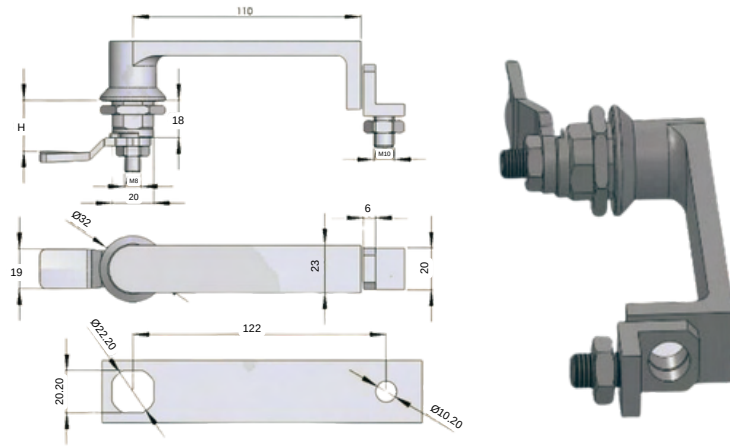

FOR PADLOCK  
2310-HT-6.1

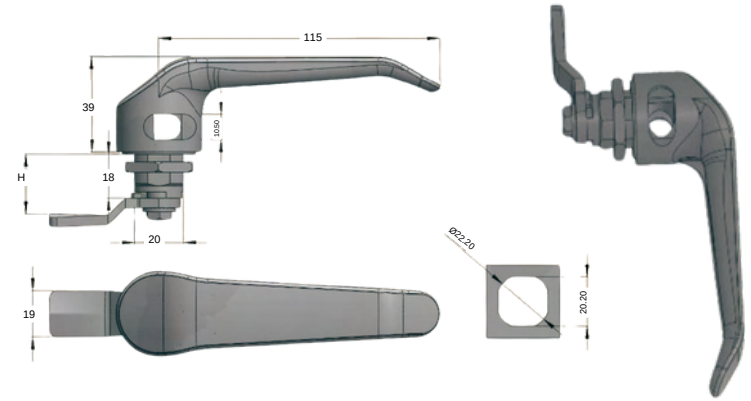

FOR PADLOCK  
2310-HT-8.1

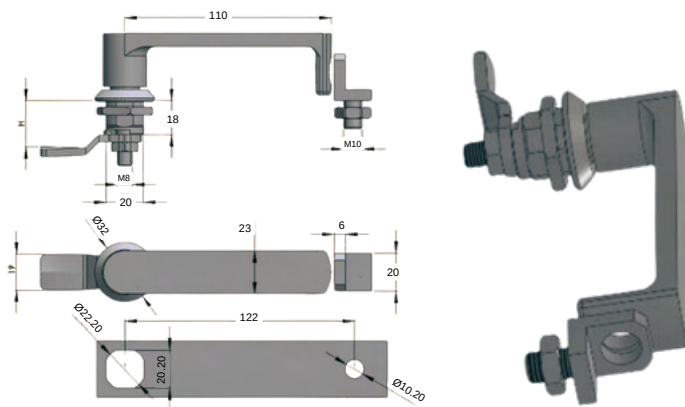

FOR PADLOCK  
2310-HT-7.1

**HANDLES**

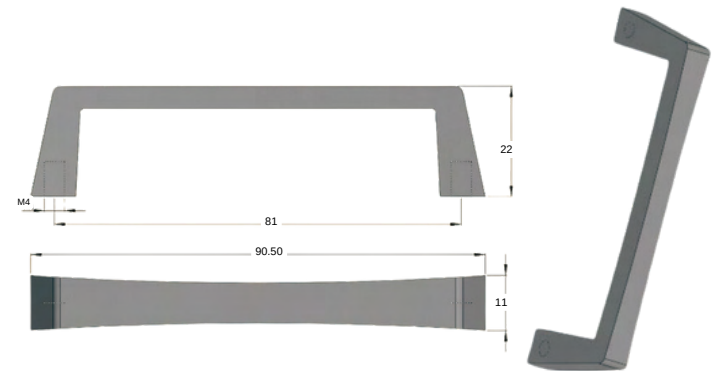

HANDLE  
2310-HT-9.1

# HANDLE HT-316



# HANDLE HT-316

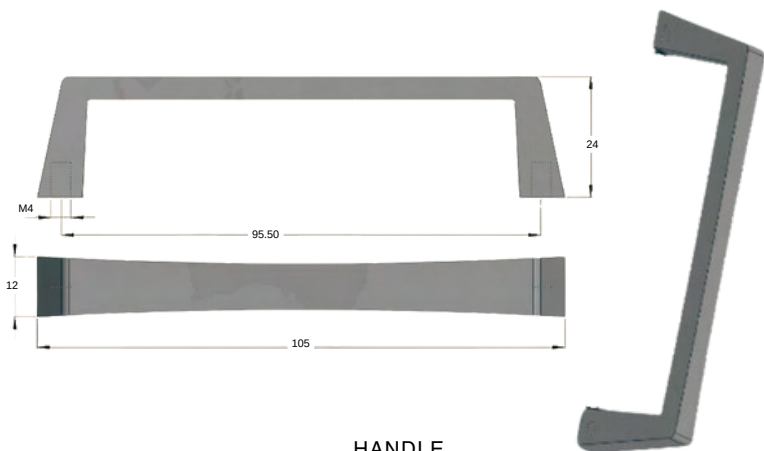

HANDLE  
2310-HT-10.1

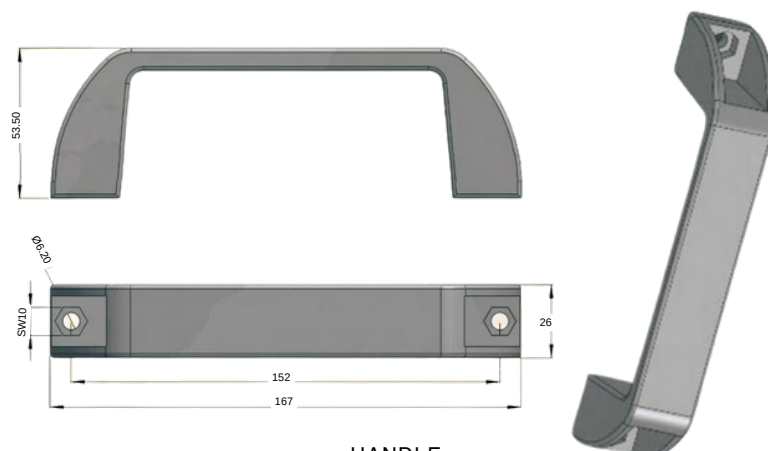

HANDLE  
2310-HT-12.1

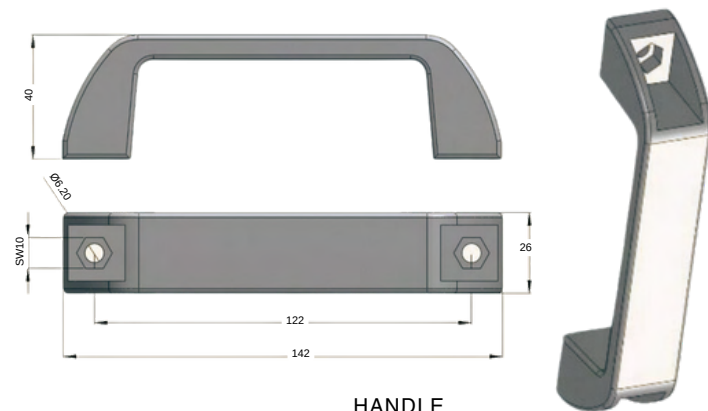

HANDLE  
2310-HT-11.1

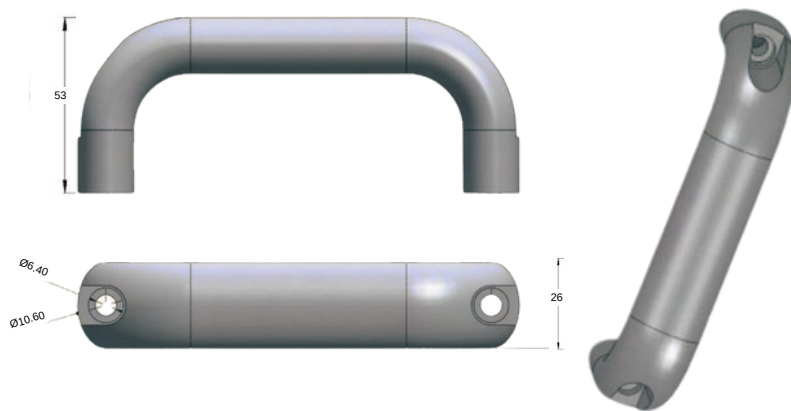

HANDLE  
2310-HT-13.1

# HANDLES



# HANDLE HT-316



# HANDLE HT-316

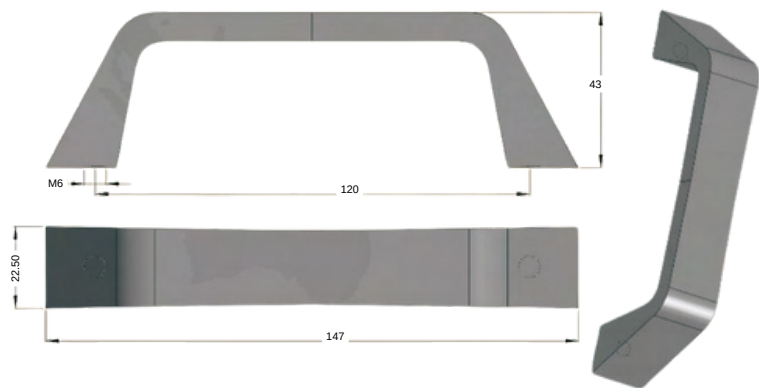

HANDLE  
2310-HT-14.1

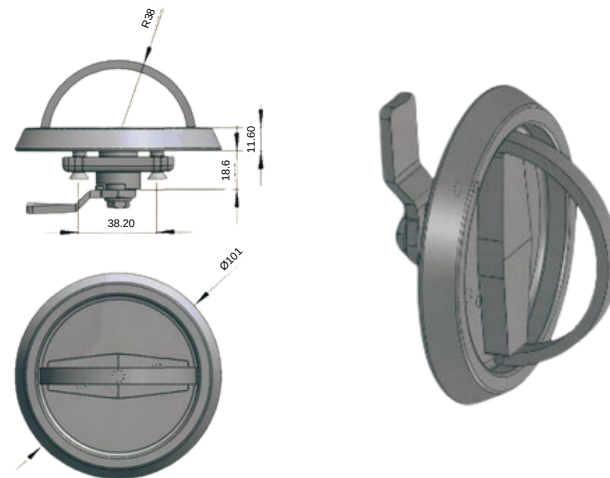

HANDLE  
2310-HT-16.1

# HANDLES

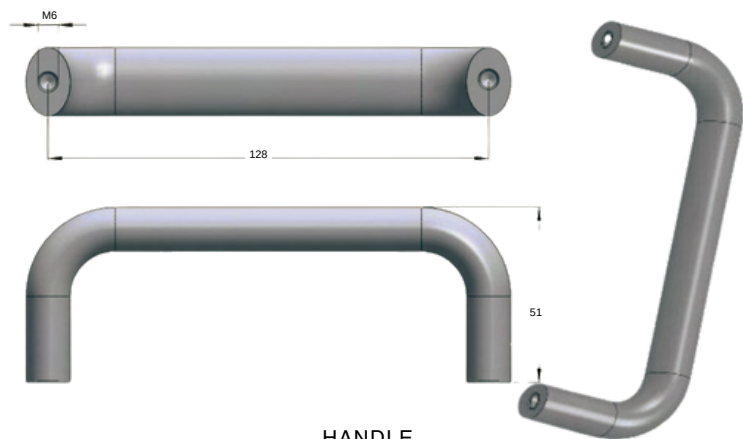

HANDLE  
2310-HT-15.1

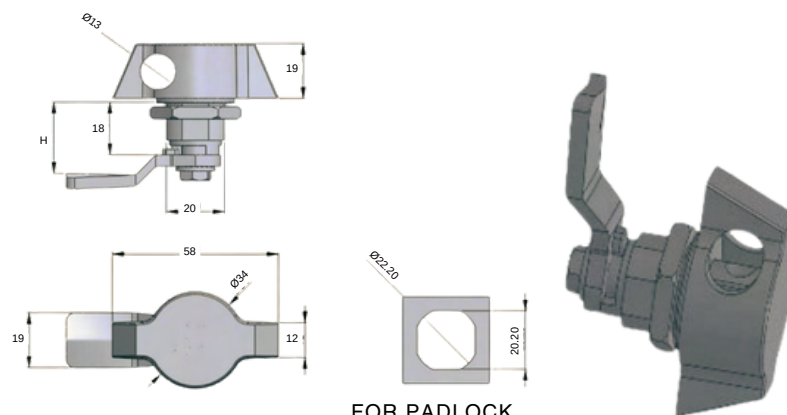

FOR PADLOCK  
2310-HT-17.1

# WING KNOB HT-316

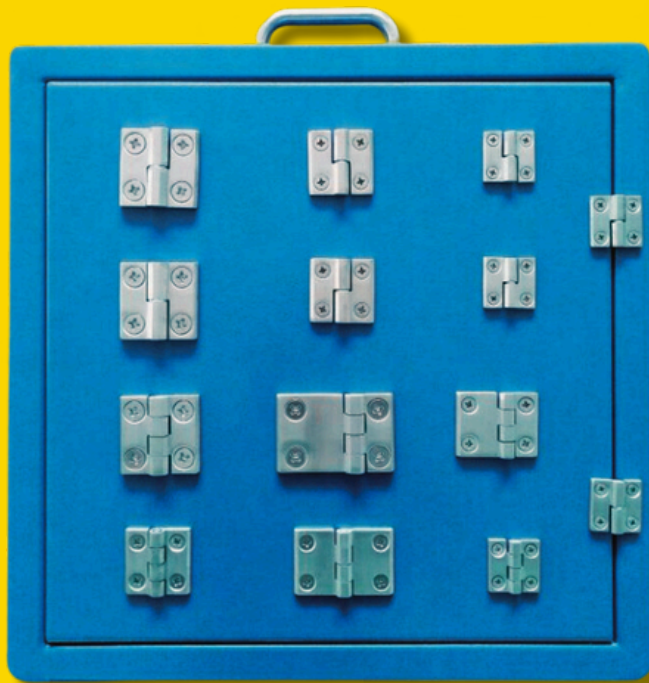

## HINGES 2715

 [www.hardwareontime.com](http://www.hardwareontime.com)  
 [Info@hardwareontime.com](mailto:Info@hardwareontime.com)  
 +861 5001 790 862

## HINGES HT-316

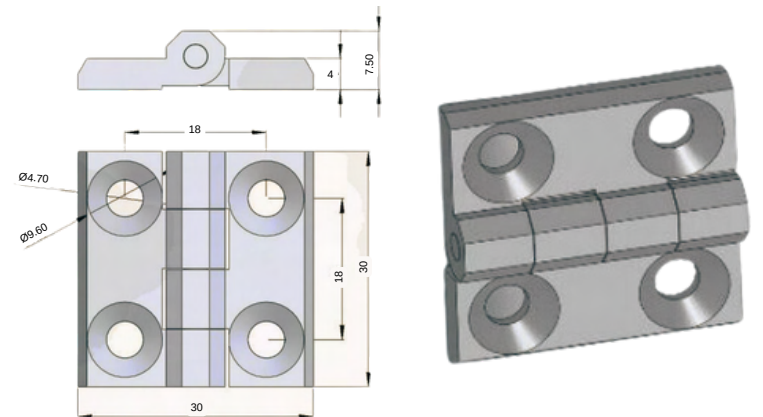

STAINLESS STEEL HINGE  
2715-HT-3.1

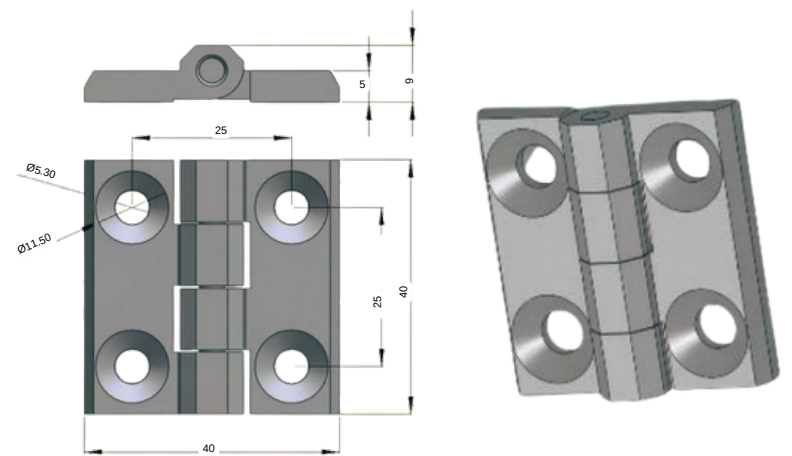

STAINLESS STEEL HINGE  
2715-HT-4.1

# HINGES HT-316



# HINGES HT-316

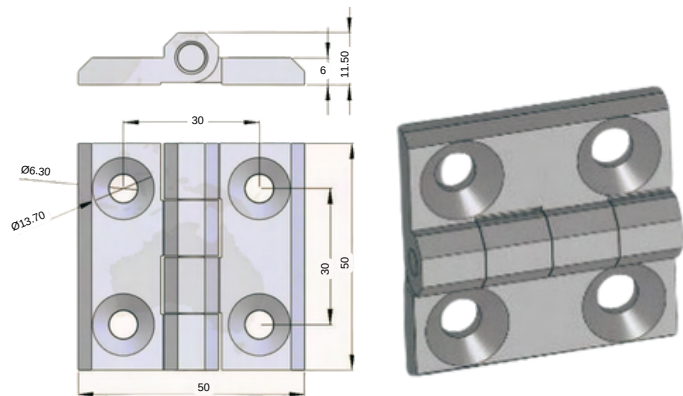

STAINLESS STEEL HINGE  
2715-HT-5.1

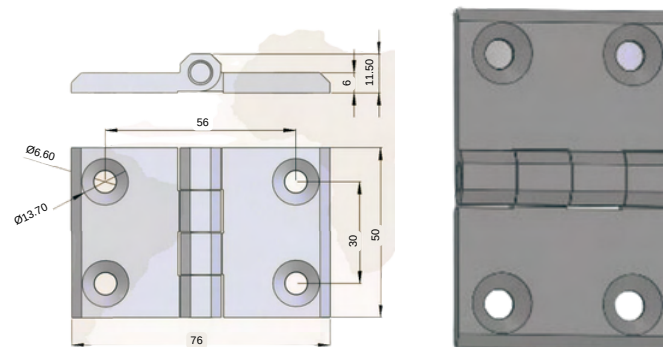

STAINLESS STEEL HINGE  
2715-HT-5.2

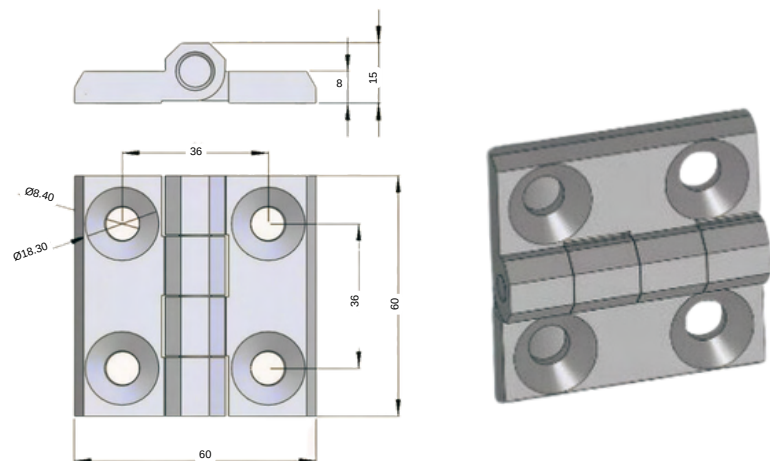

STAINLESS STEEL HINGE  
2715-HT-6.1

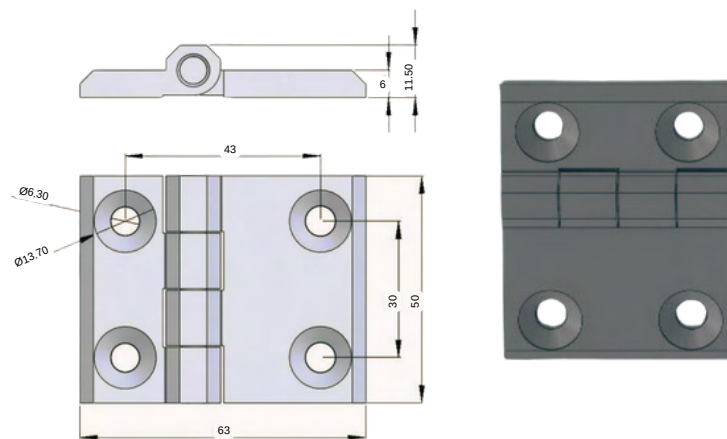

STAINLESS STEEL HINGE  
2715-HT-5.3

# HINGES 2715

# HINGES HT-316



# HINGES HT-316

# HINGES 2715

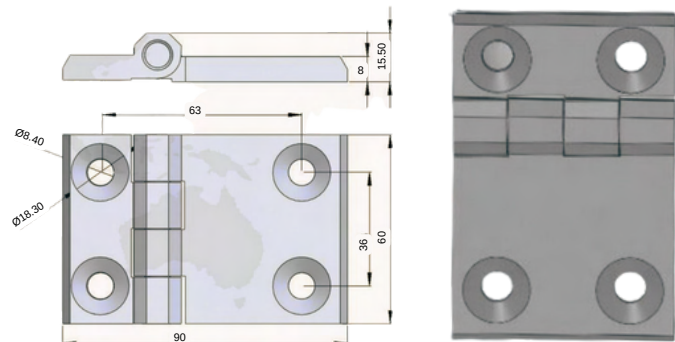

STAINLESS STEEL HINGE  
2715-HT-6.2

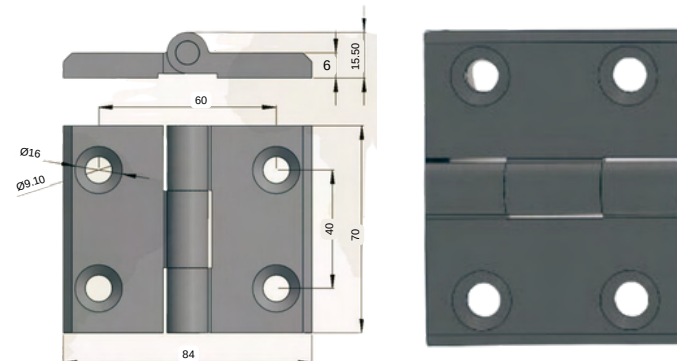

STAINLESS STEEL HINGE  
2715-HT-7.1

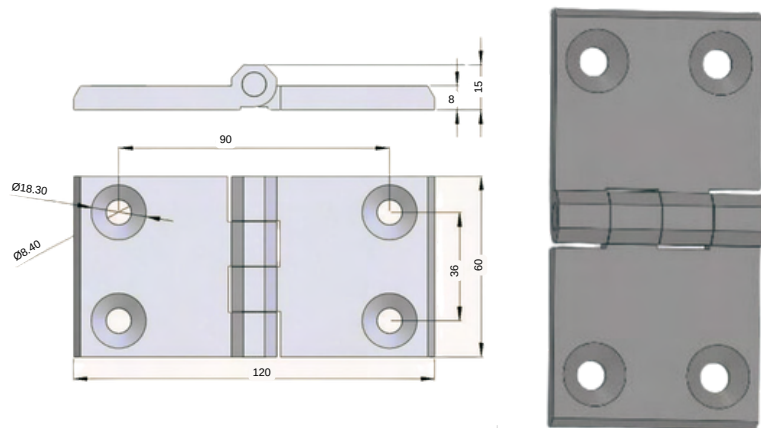

STAINLESS STEEL HINGE  
2715-HT-6.3

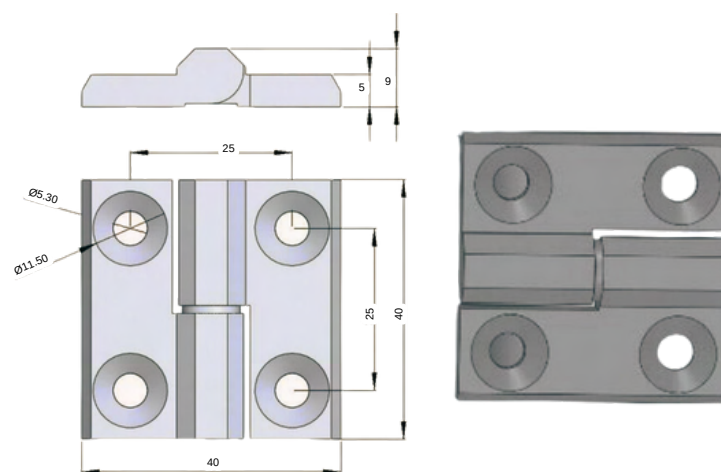

STAINLESS STEEL HINGE  
2715-HT-4.2

# HINGES HT-316



# HINGES HT-316

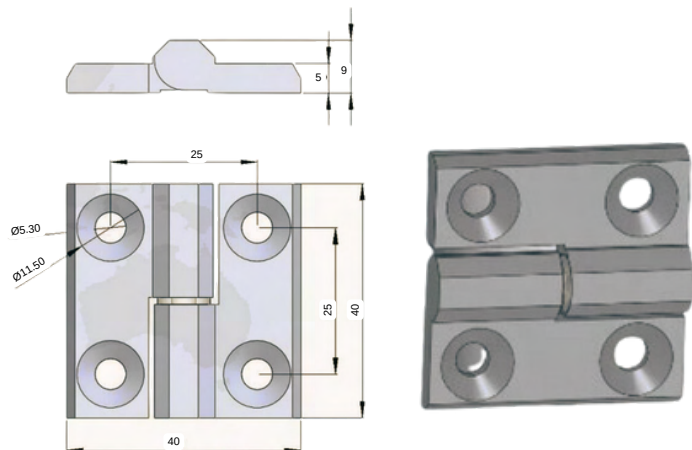

STAINLESS STEEL HINGE  
2715-HT-4.3

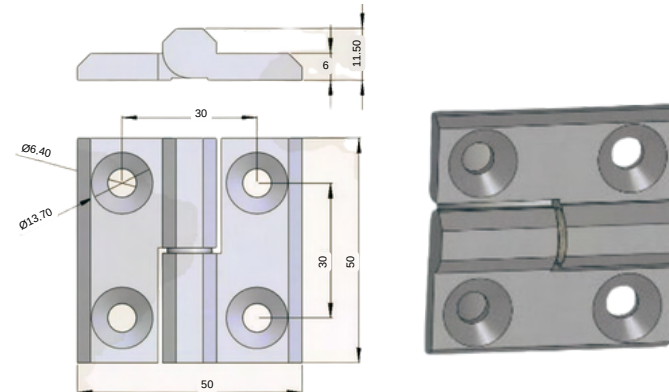

STAINLESS STEEL HINGE  
2715-HT-5.5

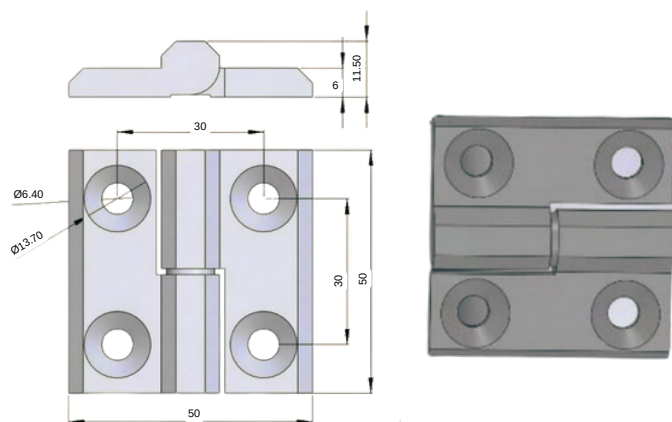

STAINLESS STEEL HINGE  
2715-HT-5.4

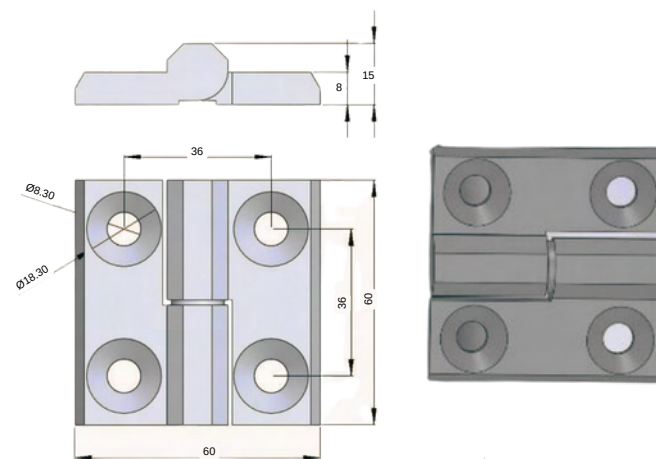

STAINLESS STEEL HINGE  
2715-HT-6.4

# HINGES 2715



# HINGES HT-316



# HINGES HT-316

# HINGES 2715

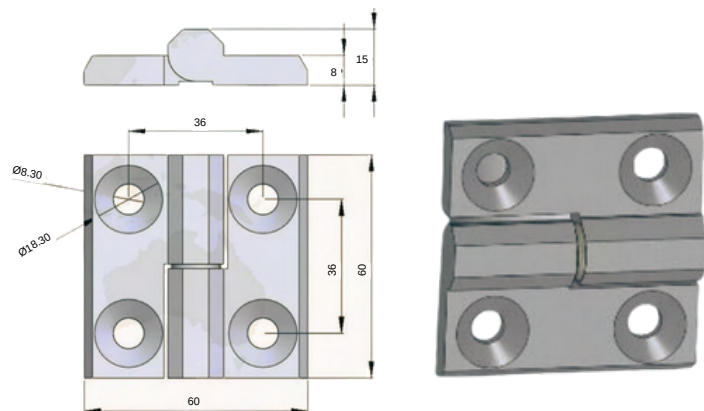

STAINLESS STEEL HINGE  
2715-HT-6.5

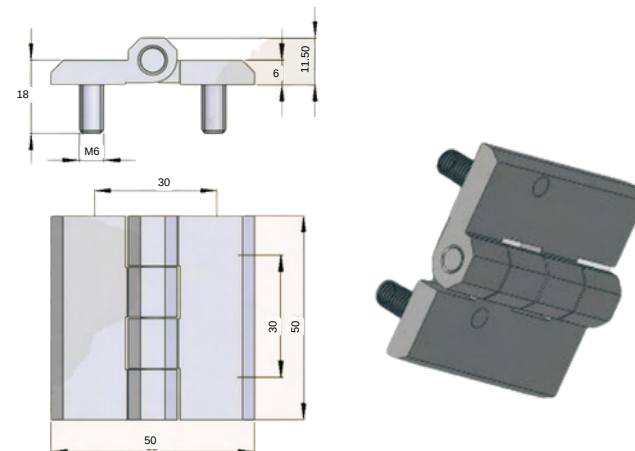

STAINLESS STEEL HINGE  
2715-HT-5.6

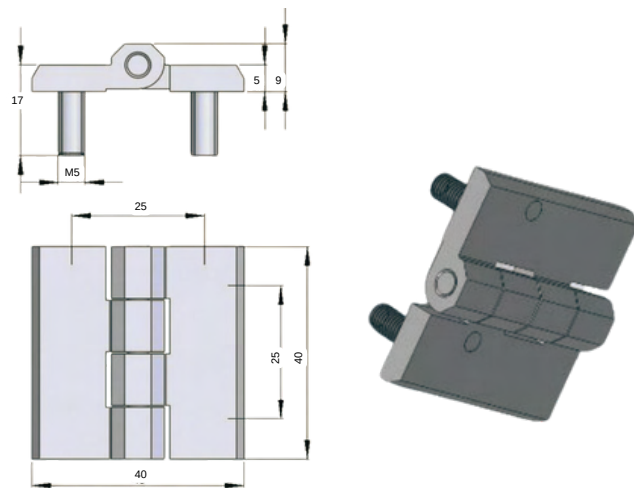

STAINLESS STEEL HINGE  
2715-HT-4.4

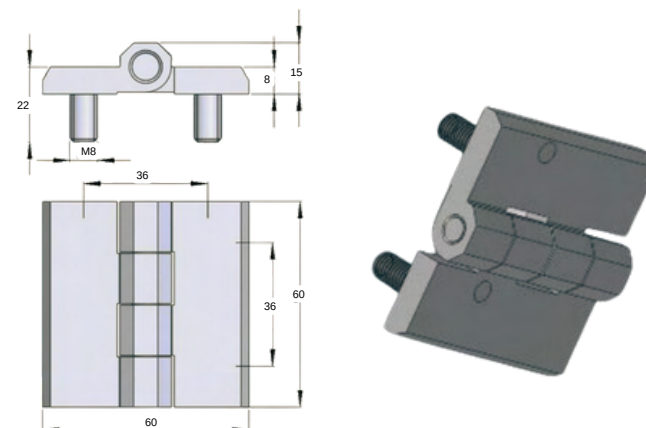

STAINLESS STEEL HINGE  
2715-HT-6.6

# HINGES HT-316



# HINGES HT-316

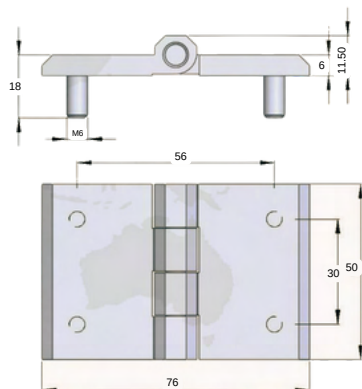

STAINLESS STEEL HINGE  
2715-HT-5.7

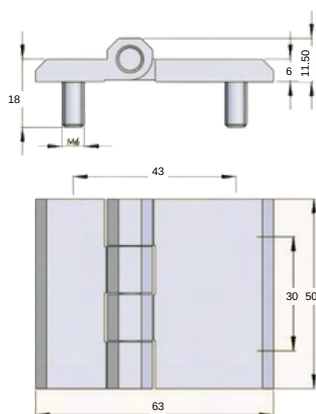

STAINLESS STEEL HINGE  
2715-HT-5.8

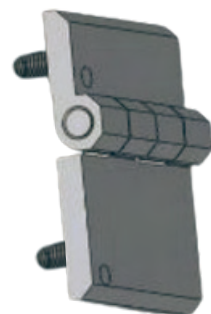

# HINGES 2715

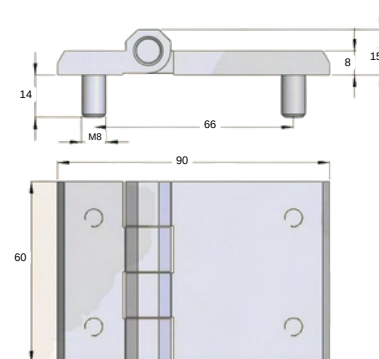

STAINLESS STEEL HINGE  
2715-HT-6.7

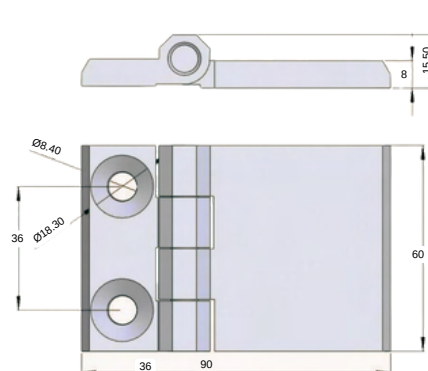
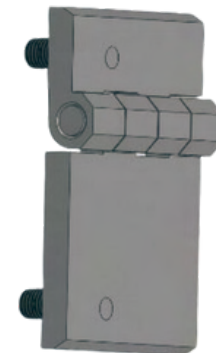

STAINLESS STEEL HINGE  
2715-HT-6.8

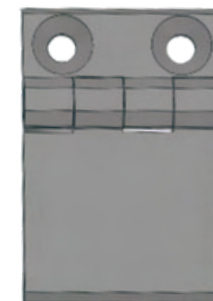



# HINGES HT-316

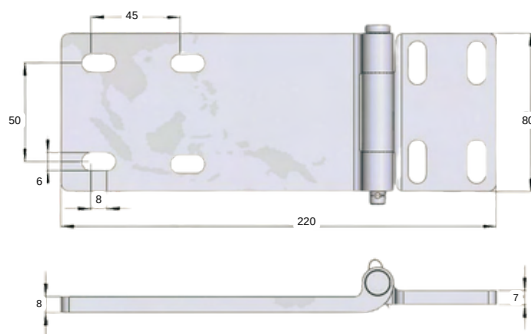

STAINLESS STEEL HINGE  
2715-HT-8.1

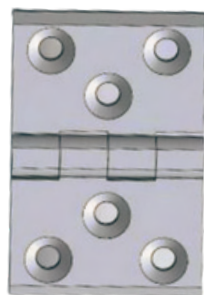
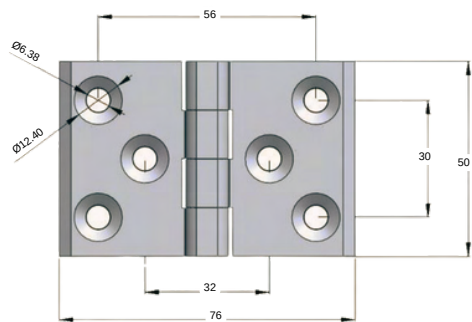

STAINLESS STEEL HINGE  
2715-HT-3.2

# HINGES 2715





## HINGES 3140

 [www.hardwareontime.com](http://www.hardwareontime.com)  
 [Info@hardwareontime.com](mailto:Info@hardwareontime.com)  
 +861 5001 790 862

## HINGES HT-316

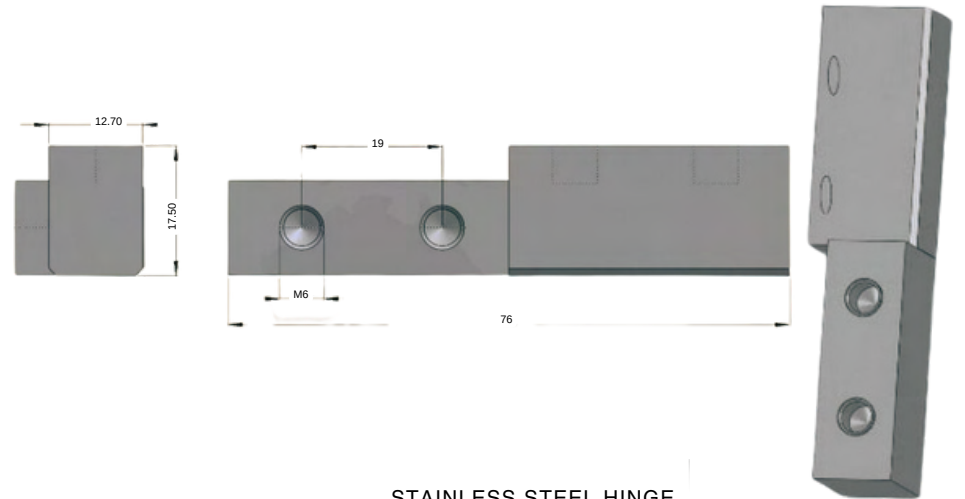

STAINLESS STEEL HINGE  
3140-HT-1.1

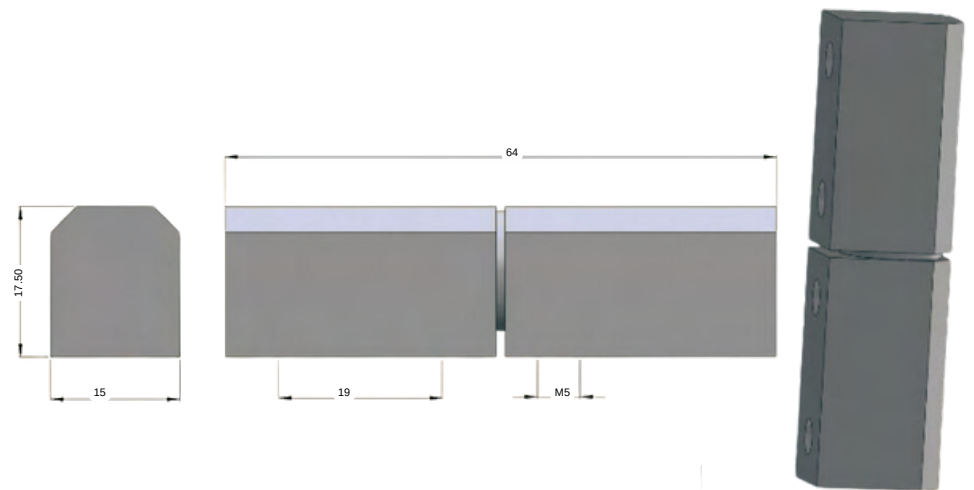

STAINLESS STEEL HINGE  
3140-HT-1.2

# HINGES HT-316



# HINGES HT-316

# HINGES 3140

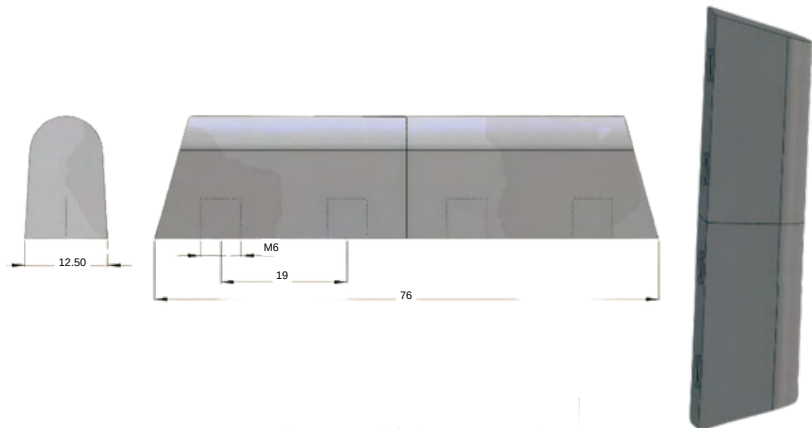

STAINLESS STEEL HINGE  
3140-HT-1.3

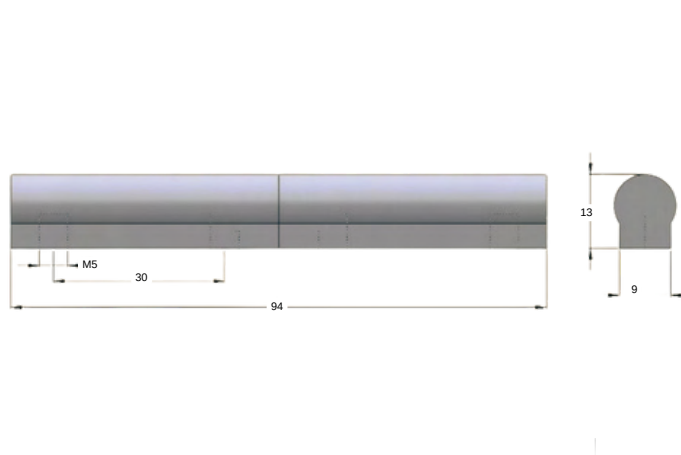

STAINLESS STEEL HINGE  
3140-HT-1.4

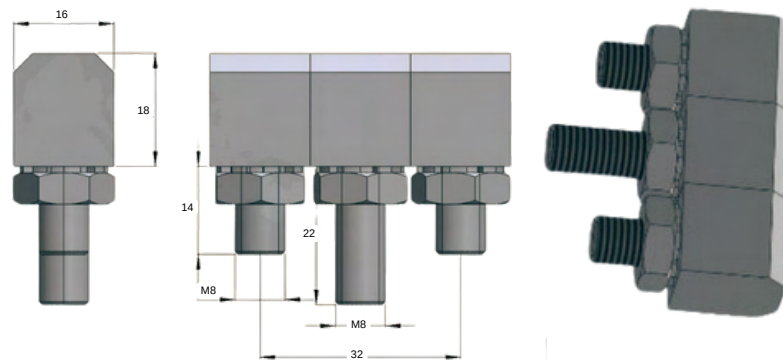

STAINLESS STEEL HINGE  
3140-HT-1.5

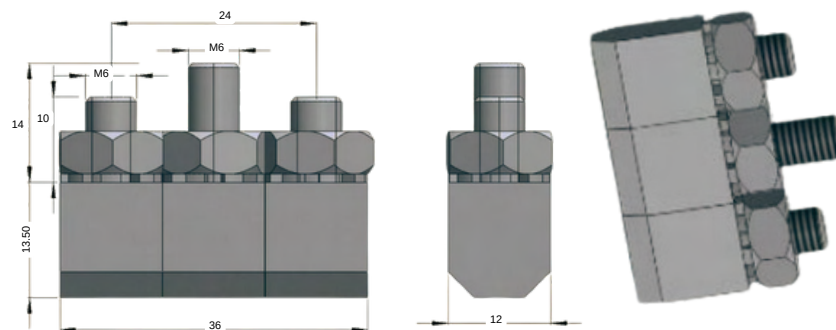

STAINLESS STEEL HINGE  
3140-HT-1.6

# HINGES HT-316



# HINGES HT-316

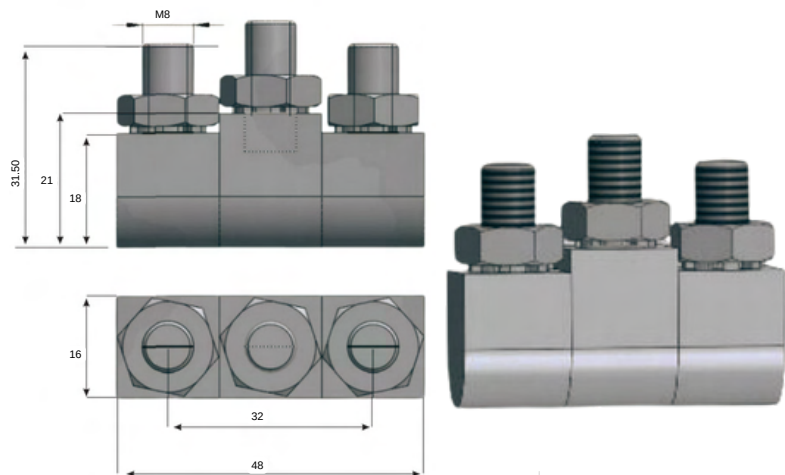

STAINLESS STEEL HINGE  
3140-HT-1.7

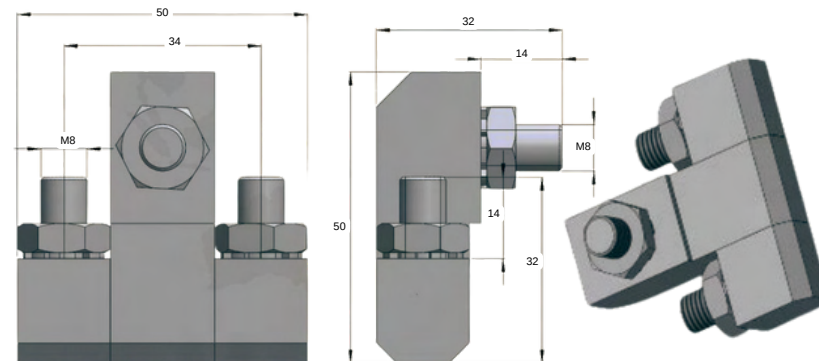

STAINLESS STEEL HINGE  
3140-HT-1.9

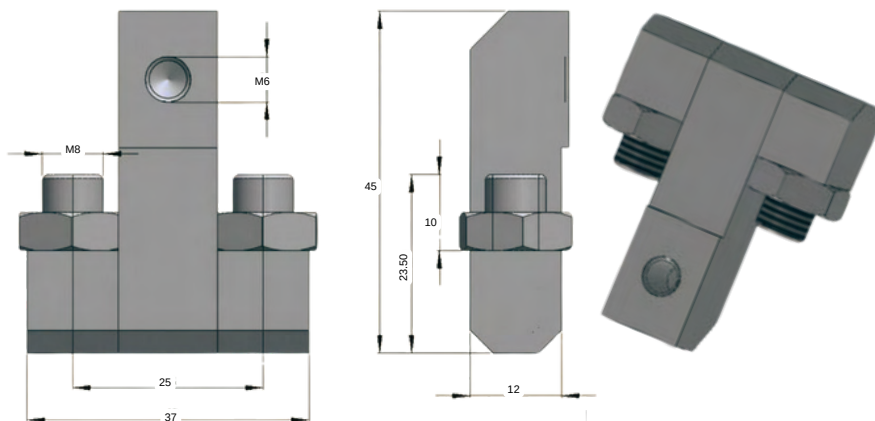

STAINLESS STEEL HINGE  
3140-HT-1.8

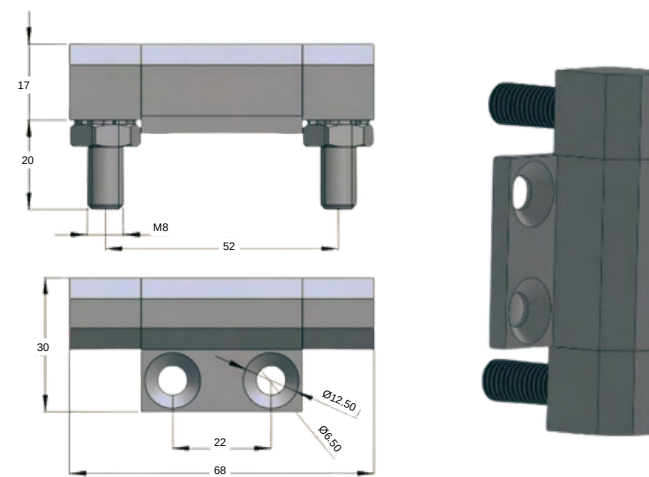

STAINLESS STEEL HINGE  
3140-HT-1.10

# HINGES 3140

# HINGES HT-316



# HINGES HT-316

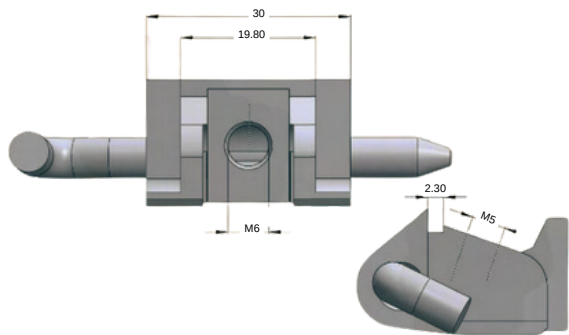

STAINLESS STEEL HINGE  
3140-HT-1.11

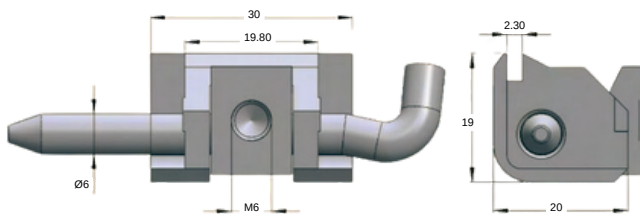
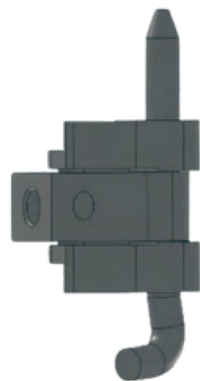

STAINLESS STEEL HINGE  
3140-HT-1.12

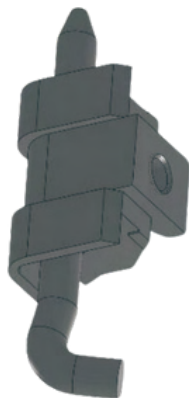

# HINGES 3140

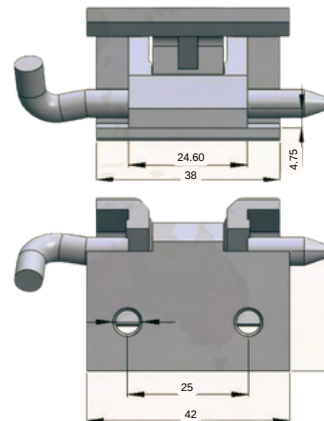

STAINLESS STEEL HINGE  
3140-HT-1.13

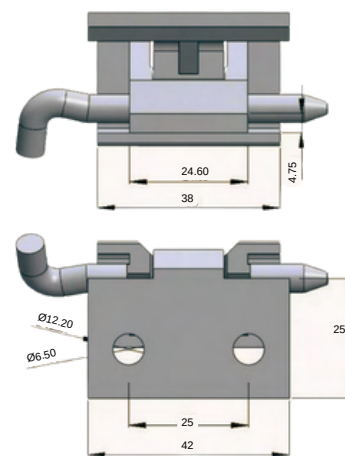
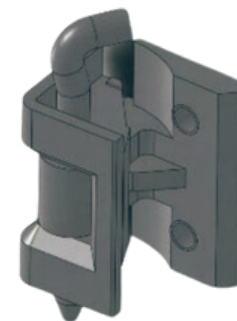

STAINLESS STEEL HINGE  
3140-HT-1.14

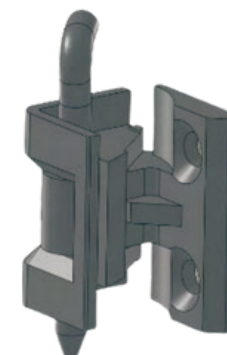

# HINGES HT-316



# HINGES HT-316

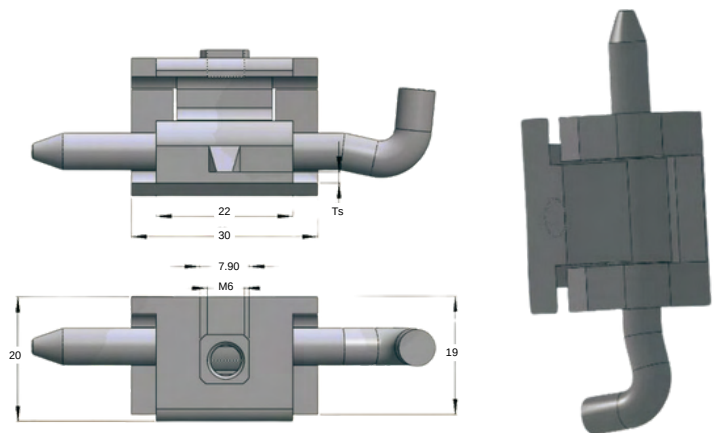

STAINLESS STEEL HINGE

3140-HT-2.1    3140-HT-2.1  
Ts=1.5        Ts=2.0

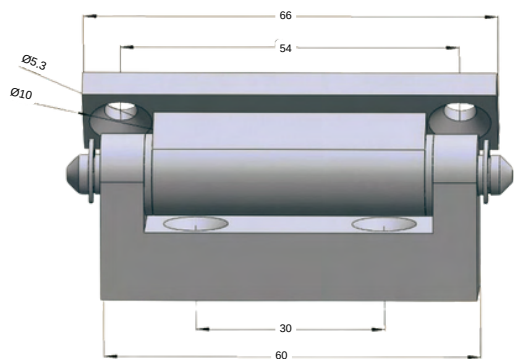

STAINLESS STEEL HINGE

3140-HT-1.15

# HINGES 3140

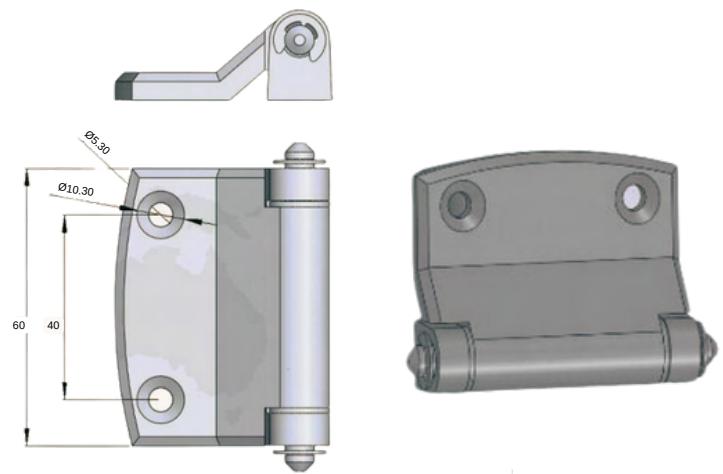

STAINLESS STEEL HINGE

3140-HT-1.16

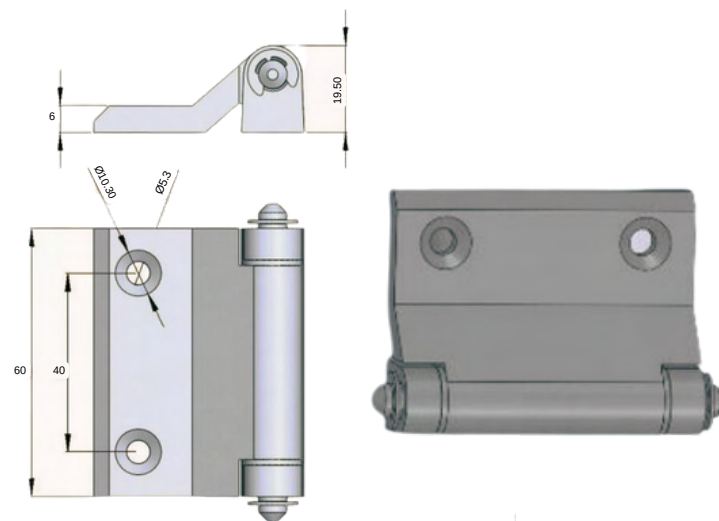

STAINLESS STEEL HINGE

3140-HT-1.17



# HINGES HT-316



# HINGES HT-316

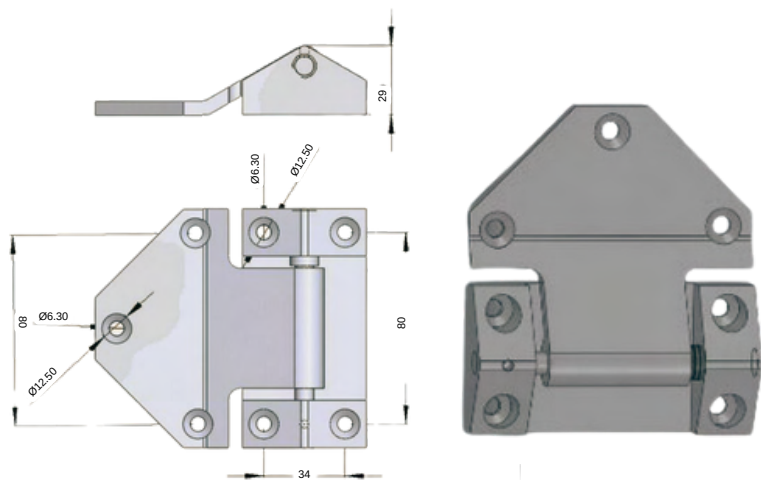

STAINLESS STEEL HINGE  
3140-HT-1.18

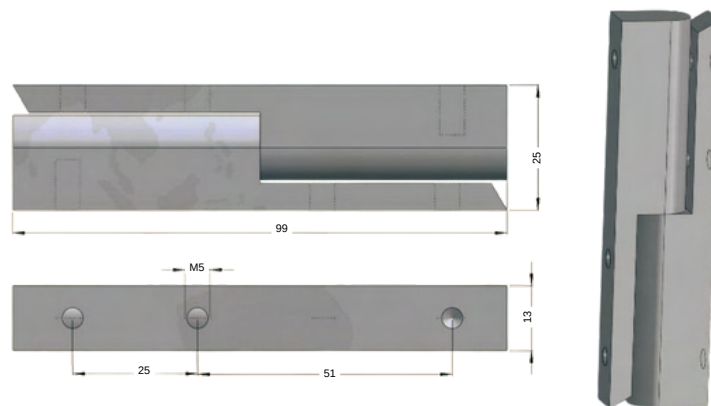

STAINLESS STEEL HINGE  
3140-HT-1.20

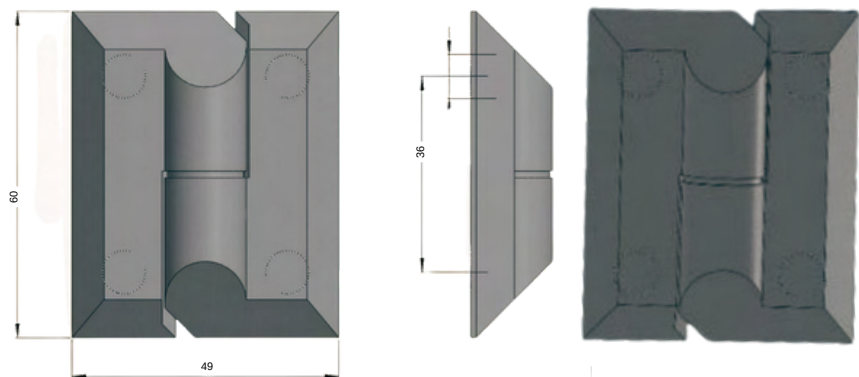

STAINLESS STEEL HINGE  
3140-HT-1.19

# HINGES 3140

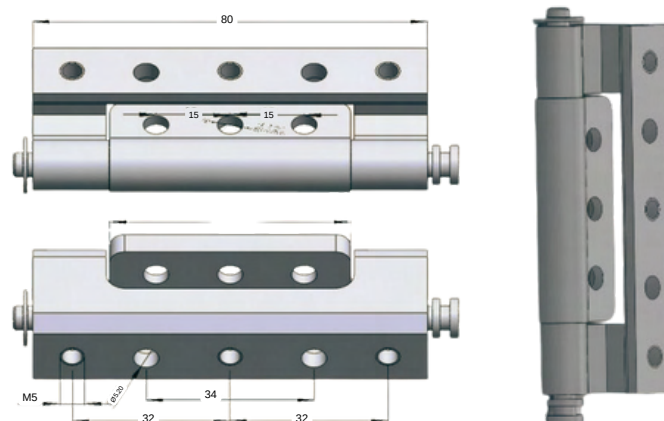

STAINLESS STEEL HINGE  
3140-HT-1.21



**HINGES HT-316**

**HDT**  
HARDWAREONTIME

**HINGES HT-316**

**HINGES 3140**

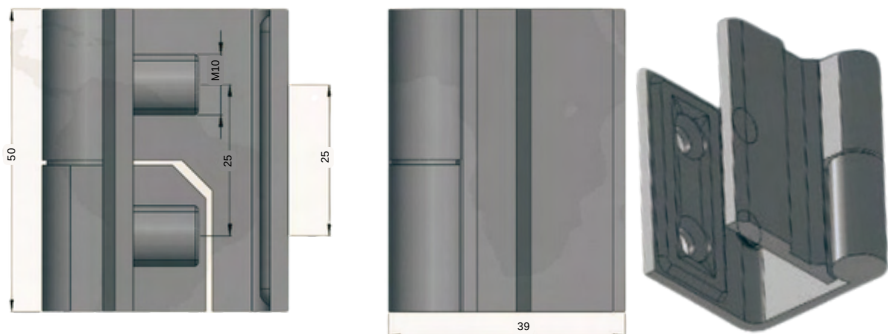

STAINLESS STEEL HINGE  
3140-HT-1.22

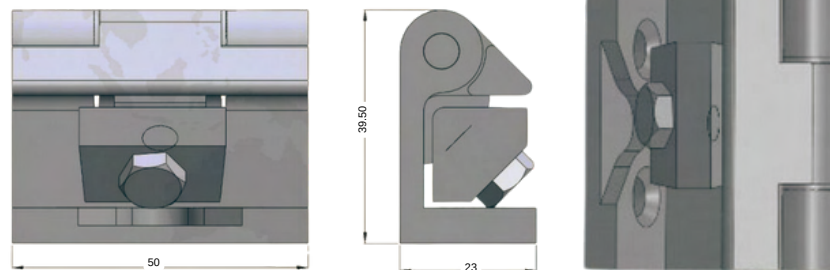

STAINLESS STEEL HINGE  
3140-HT-1.24



STAINLESS STEEL HINGE  
3140-HT-1.23

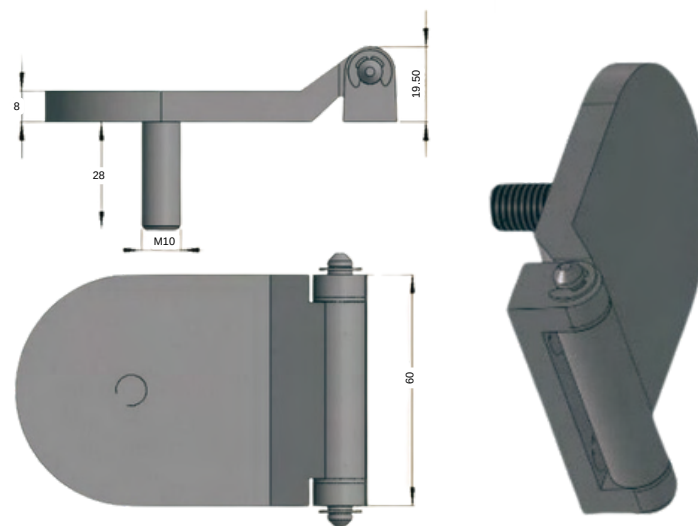

STAINLESS STEEL HINGE  
3140-HT-1.25

# HINGES HT-316



# HINGES HT-316

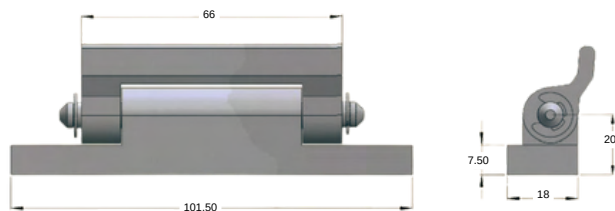

STAINLESS STEEL HINGE  
3140-HT-1.26



# HINGES 3140

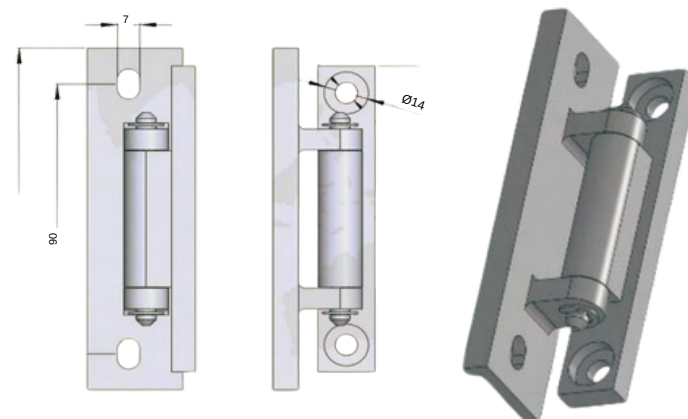

STAINLESS STEEL HINGE  
3140-HT-1.28

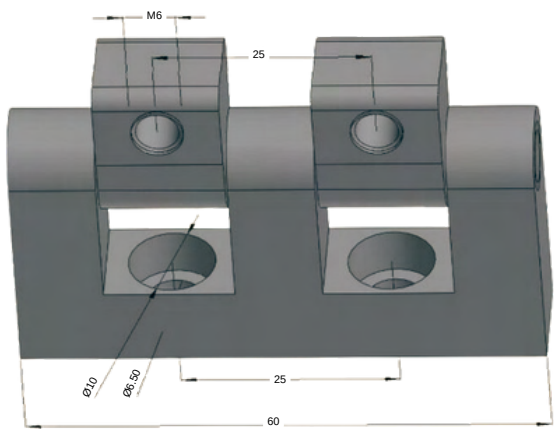

STAINLESS STEEL HINGE  
3140-HT-1.27

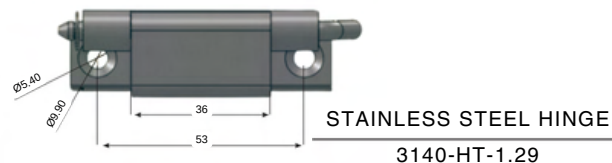
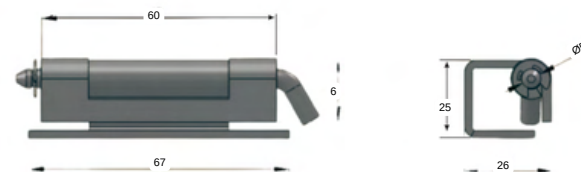

STAINLESS STEEL HINGE  
3140-HT-1.29





**QUARTER TURN**

**QUARTER TURN HT-316**

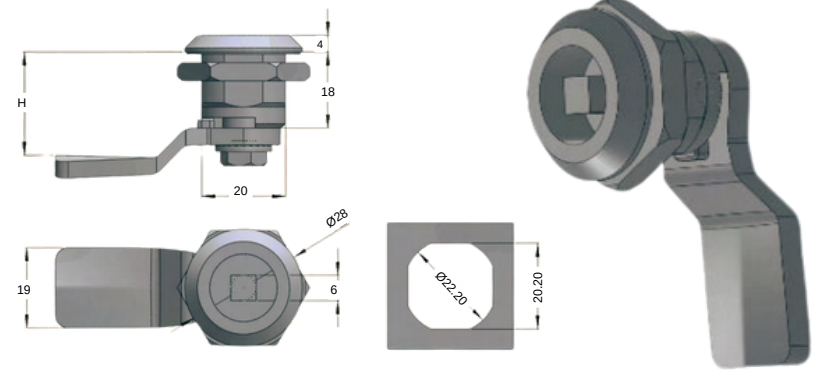

STAINLESS STEEL QUARTER TURN  
2513-HT-4.1

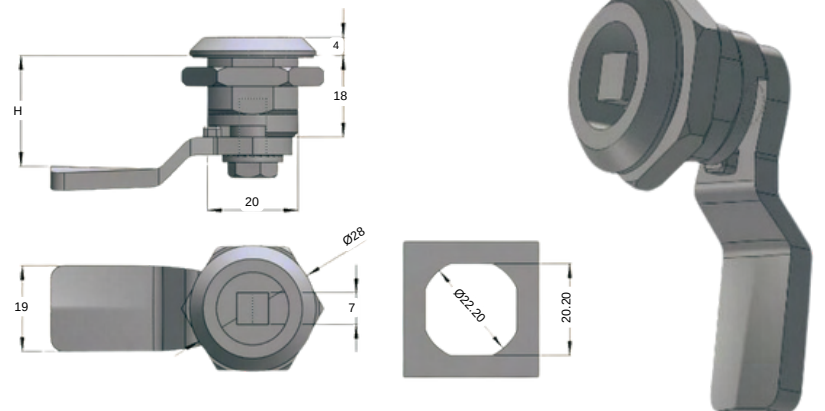

STAINLESS STEEL QUARTER TURN  
2513-HT-4.2

# QUARTER TURN HT-316



# QUARTER TURN HT-316

# QUARTER TURN

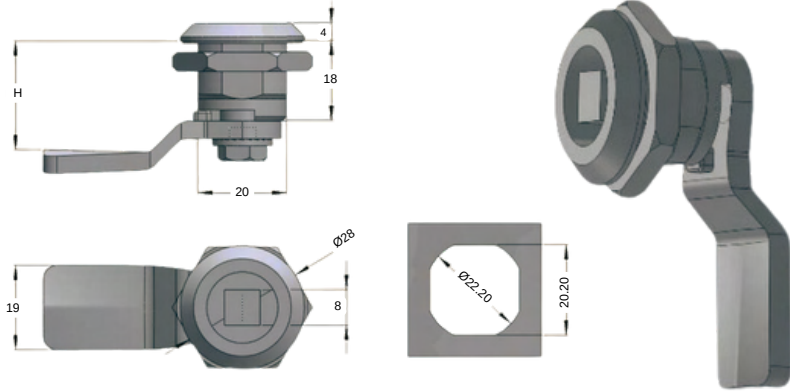

STAINLESS STEEL QUARTER TURN  
2513-HT-4.3

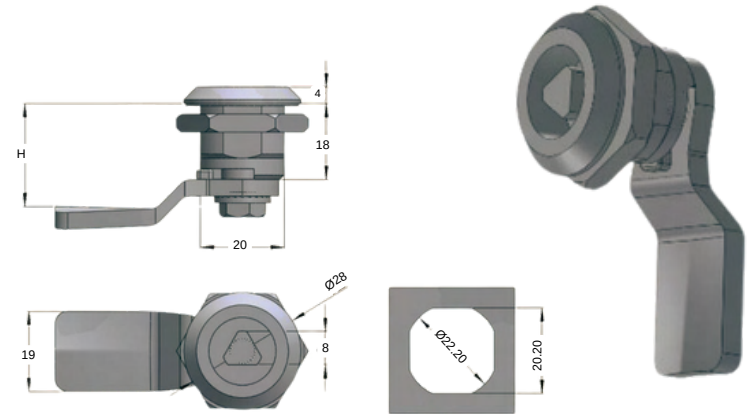

STAINLESS STEEL QUARTER TURN  
2513-HT-3.2

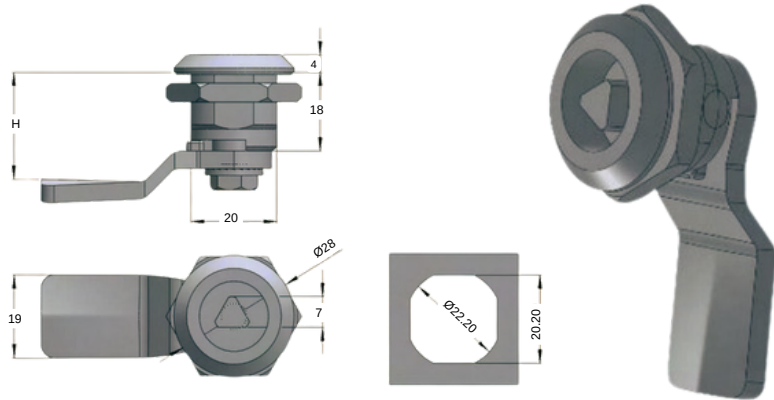

STAINLESS STEEL QUARTER TURN  
2513-HT-3.1

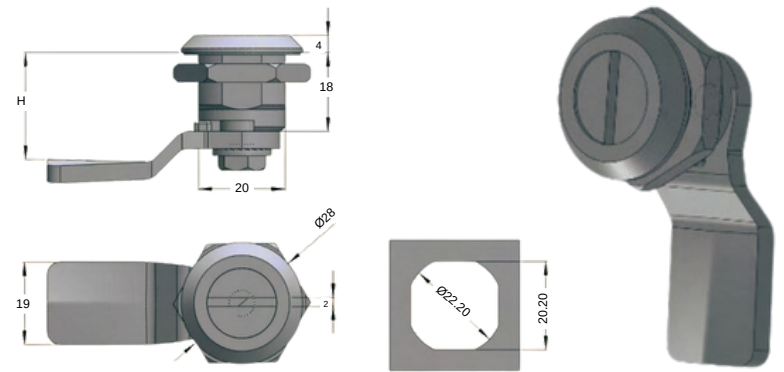

STAINLESS STEEL QUARTER TURN  
2513-HT-1.1

# QUARTER TURN HT-316



# QUARTER TURN HT-316

# QUARTER TURN

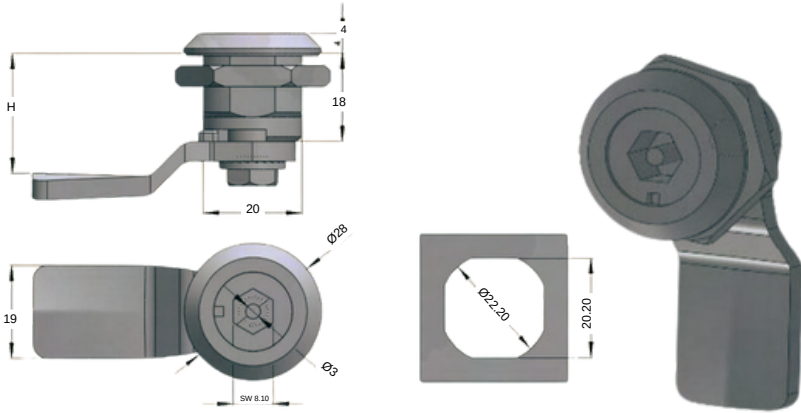

STAINLESS STEEL QUARTER TURN  
2513-HT-6.1

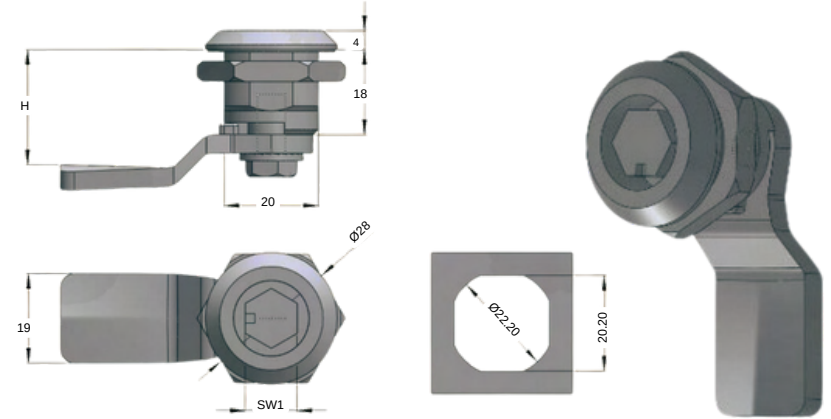

STAINLESS STEEL QUARTER TURN  
2513-HT-6.3

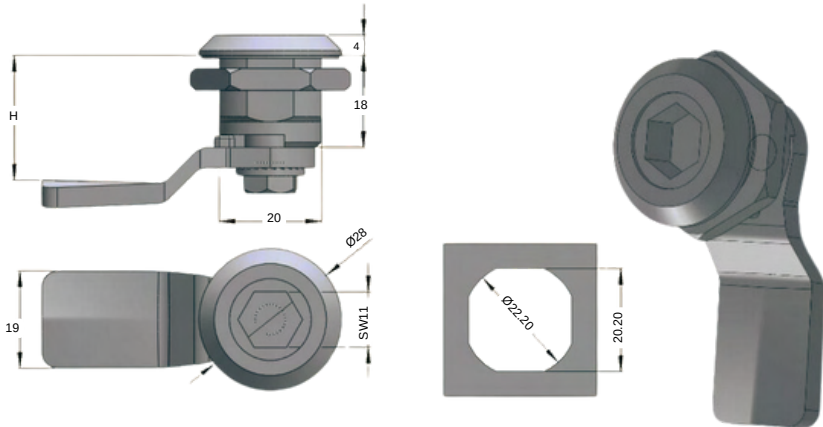

STAINLESS STEEL QUARTER TURN  
2513-HT-6.2

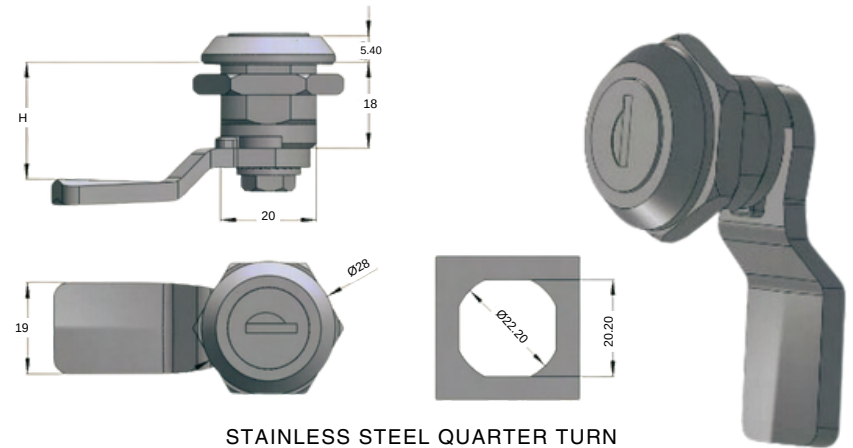

STAINLESS STEEL QUARTER TURN  
2513-HT-1.2



# QUARTER TURN HT-316



# QUARTER TURN HT-316

# QUARTER TURN

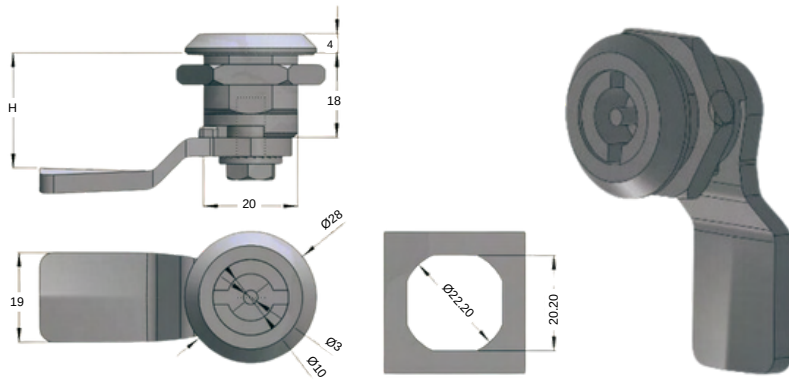

STAINLESS STEEL QUARTER TURN  
2513-HT-2.1

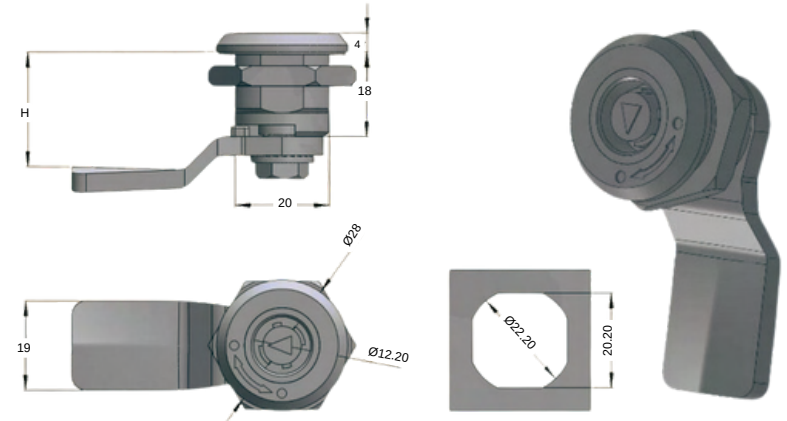

STAINLESS STEEL QUARTER TURN  
2513-HT-1.3

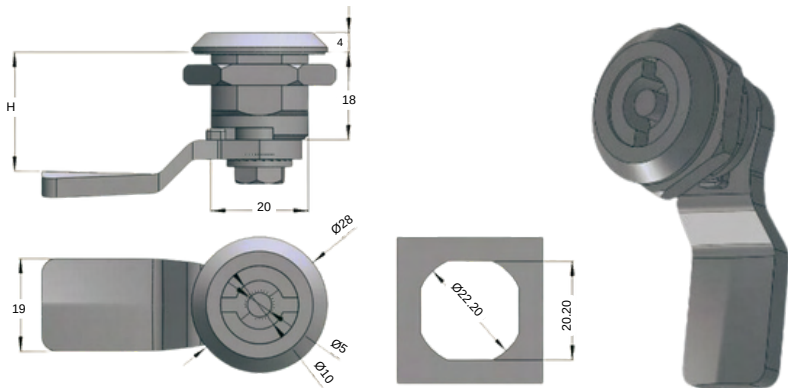

STAINLESS STEEL QUARTER TURN  
2513-HT-2.2

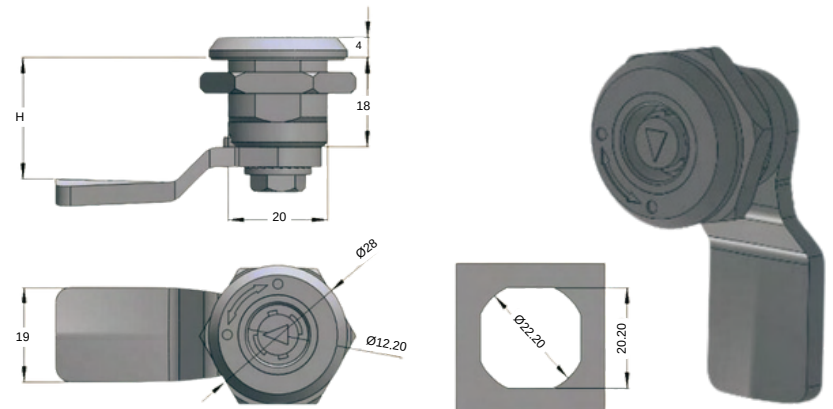

STAINLESS STEEL QUARTER TURN  
2513-HT-1.4

# QUARTER TURN HT-316



# QUARTER TURN

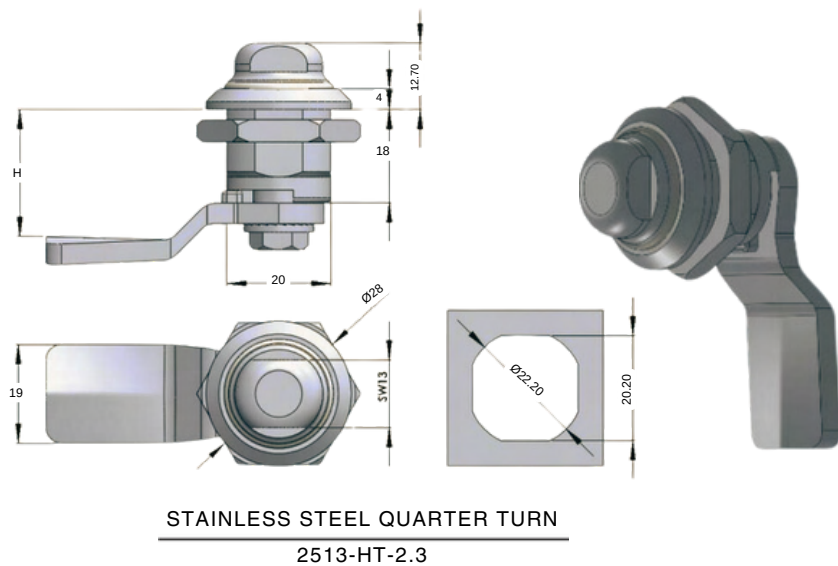
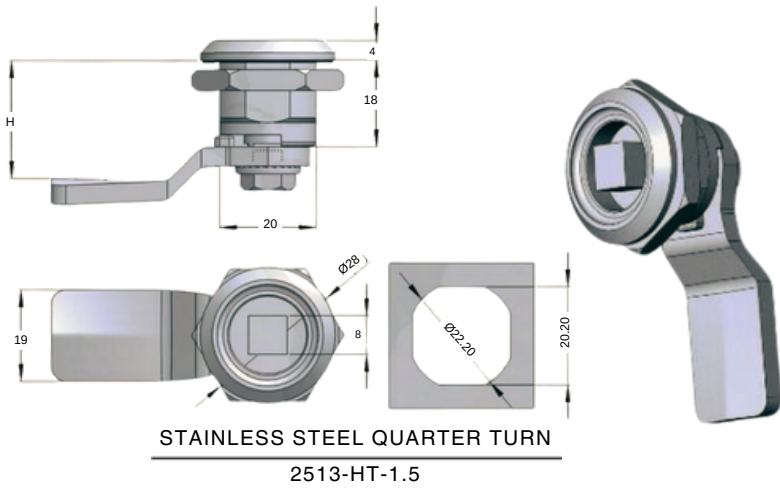





## SECURITY QUARTER TURN

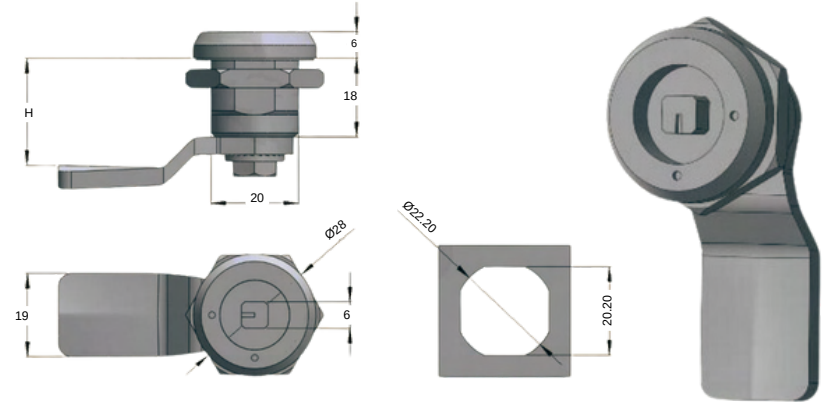

STAINLESS STEEL QUARTER TURN  
2514-HT-4.1

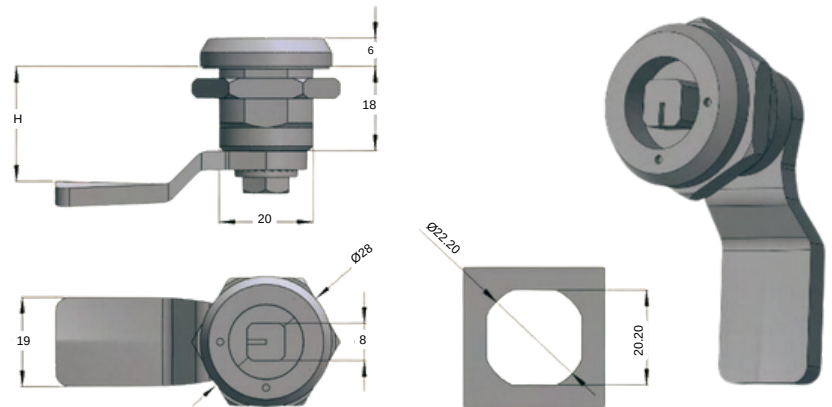

STAINLESS STEEL QUARTER TURN  
2514-HT-4.2

# SECURITY QUARTER TURN HT-316



# SECURITY QUARTER TURN HT-316

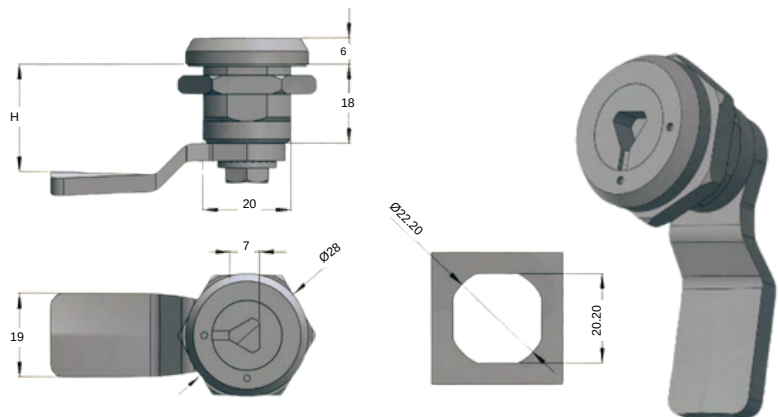

STAINLESS STEEL QUARTER TURN  
2514-HT-3.1

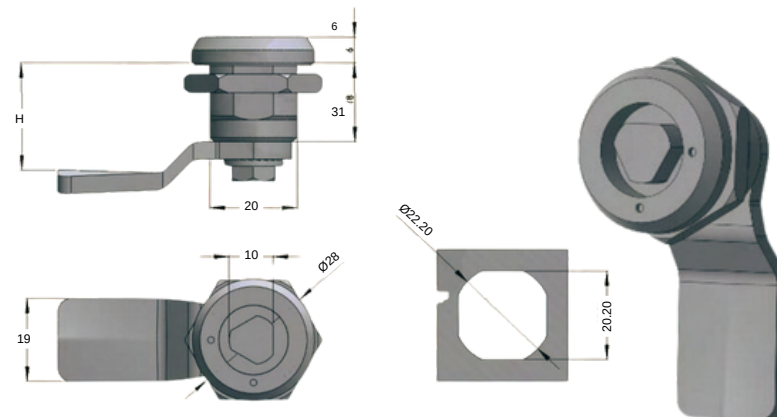

STAINLESS STEEL QUARTER TURN  
2514-HT-3.3

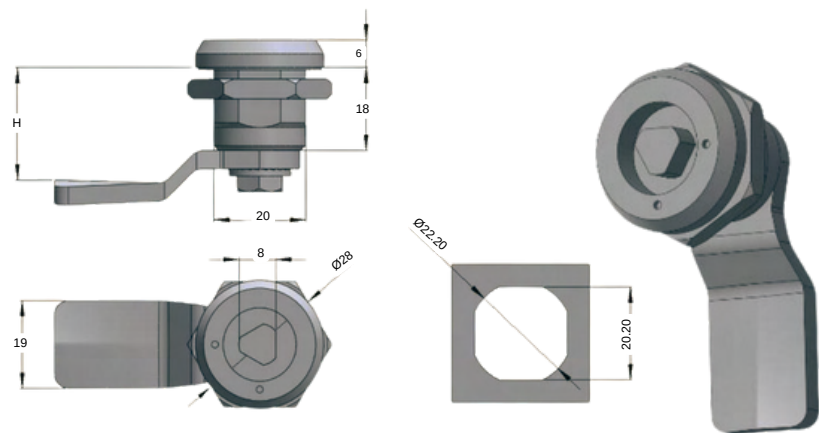

STAINLESS STEEL QUARTER TURN  
2514-HT-3.2

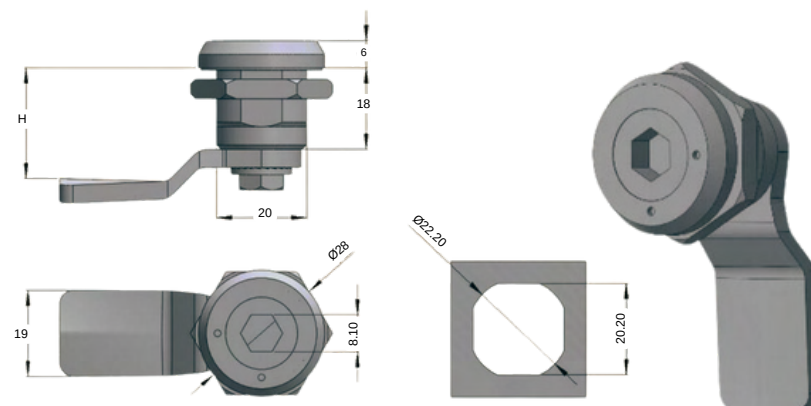

STAINLESS STEEL QUARTER TURN  
2514-HT-6.1

SECURITY QUARTER TURN



## COMPRESSION LATCH

## COMPRESSION LATCH HT-316

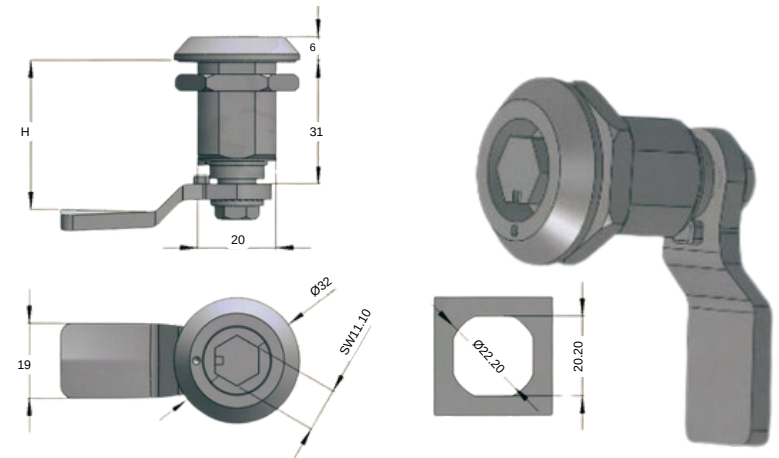

2413-HT-6.1

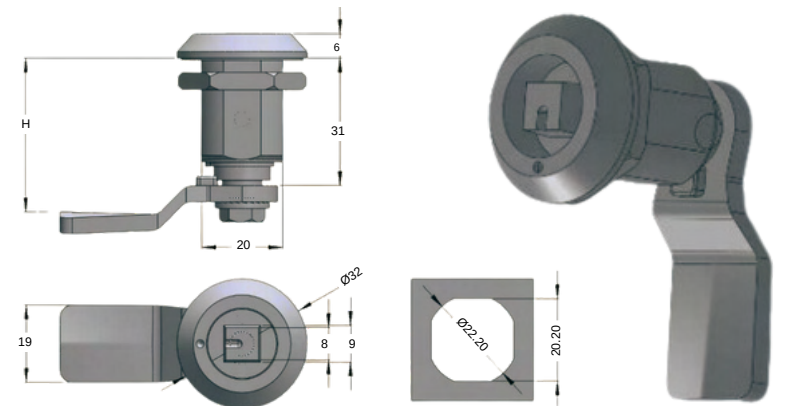

2413-HT-4.1

# COMPRESSION LATCH HT-316



# SECURITY QUARTER TURN HT-316

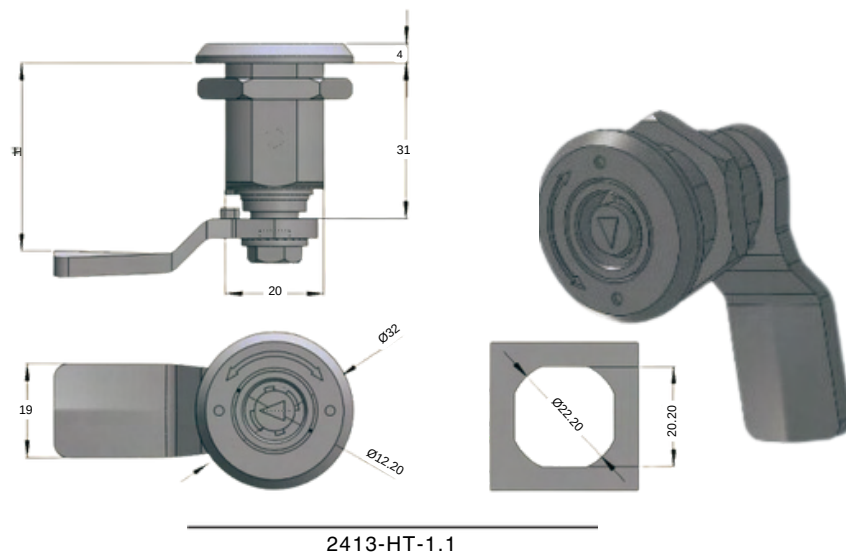
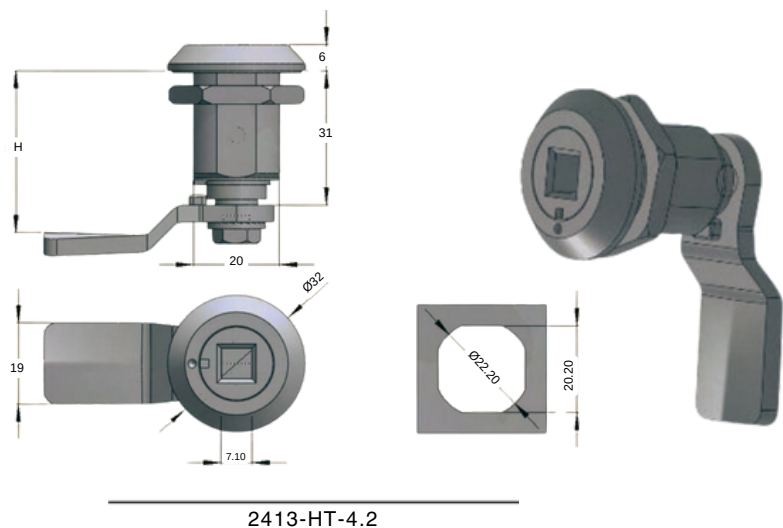

COMPRESSION LATCH

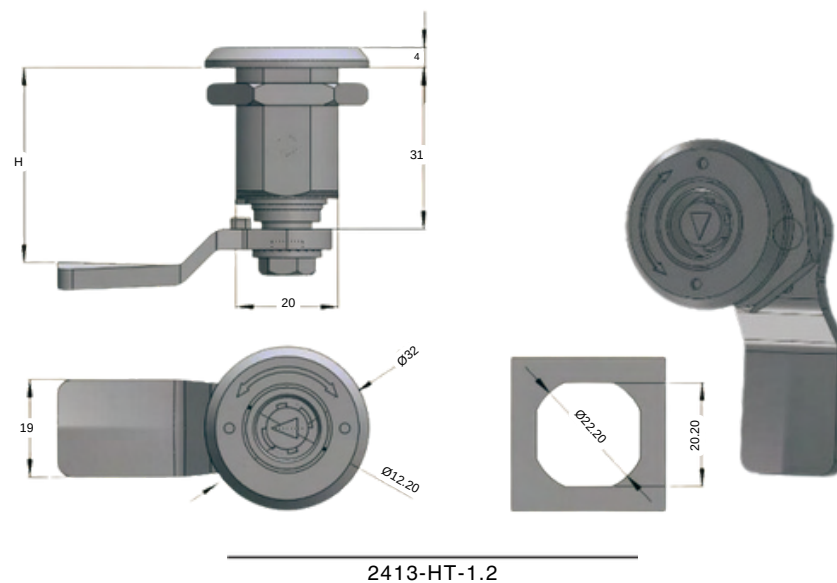
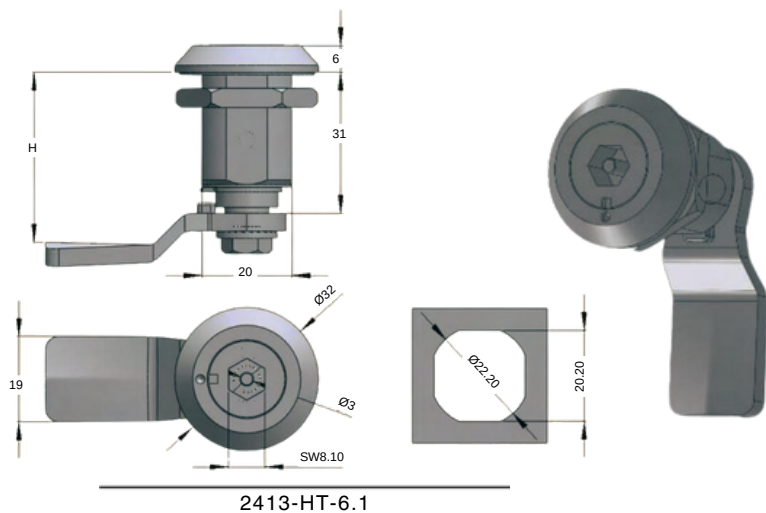

**COMPRESSION LATCH**  
**HT-316**



**SECURITY QUARTER TURN**  
**HT-316**

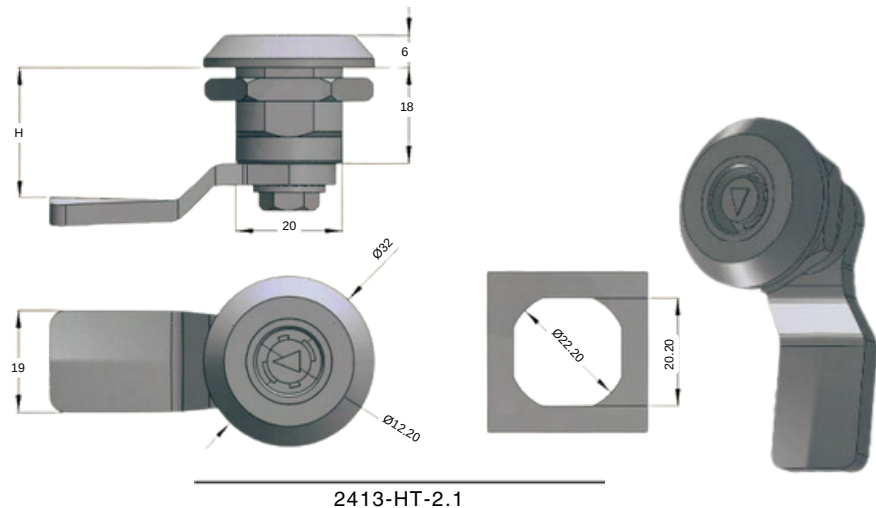

2413-HT-2.1

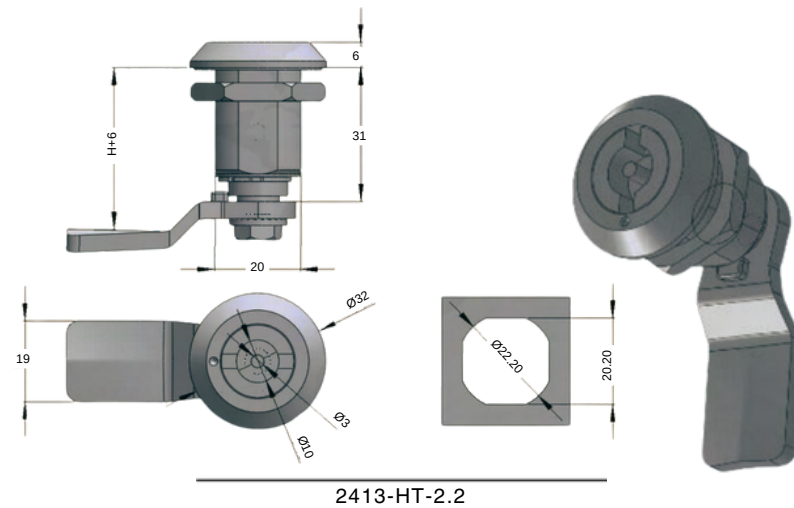

2413-HT-2.2

**COMPRESSION LATCH**

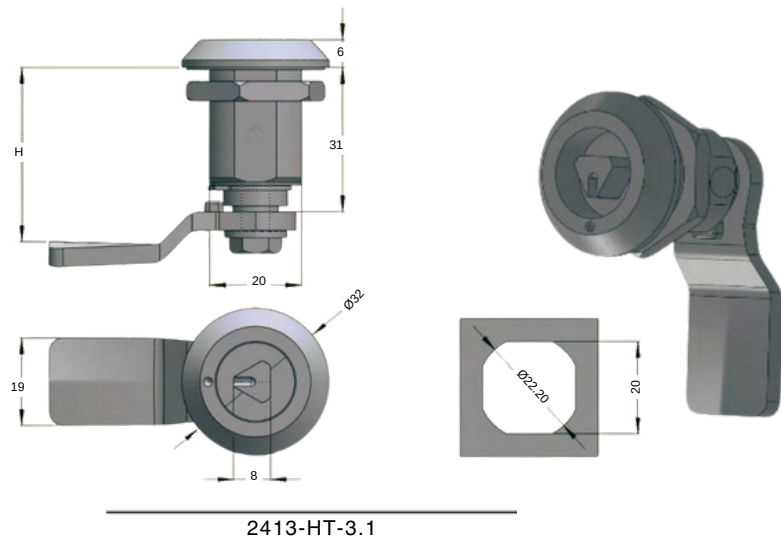

2413-HT-3.1

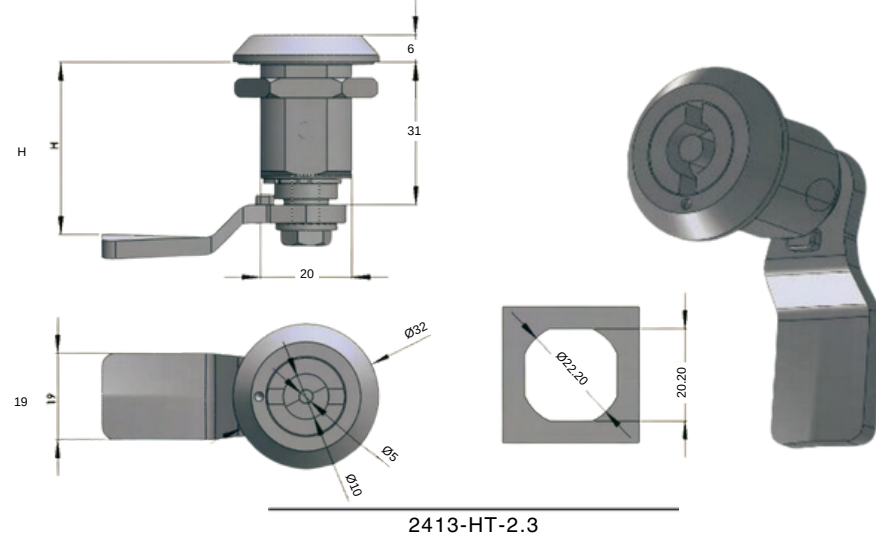

2413-HT-2.3



**COMPRESSION LATCH**  
**HT-316**



**SECURITY QUARTER TURN**  
**HT-316**

**COMPRESSION LATCH**

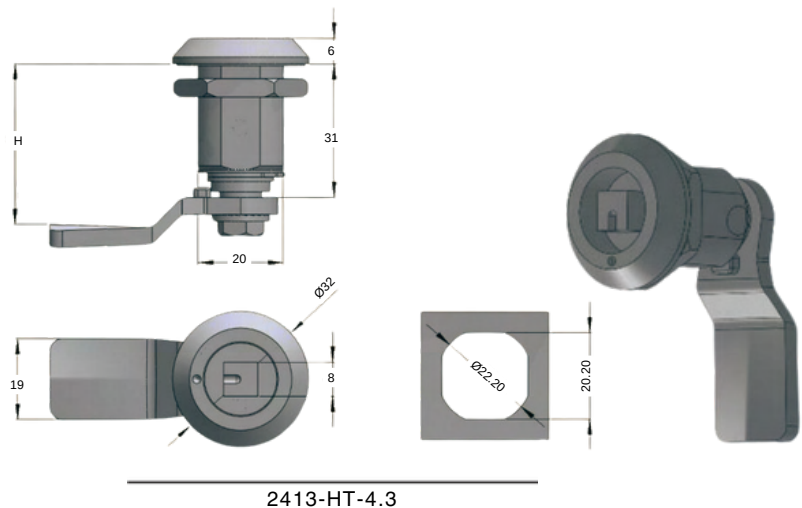

2413-HT-4.3

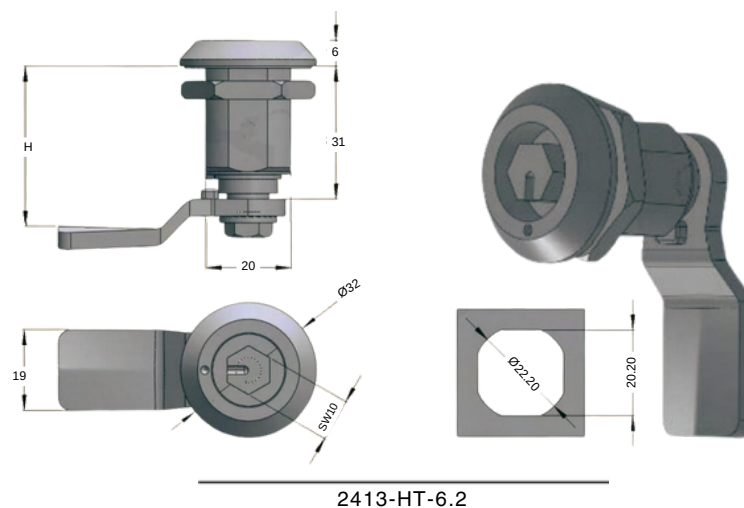

2413-HT-6.2

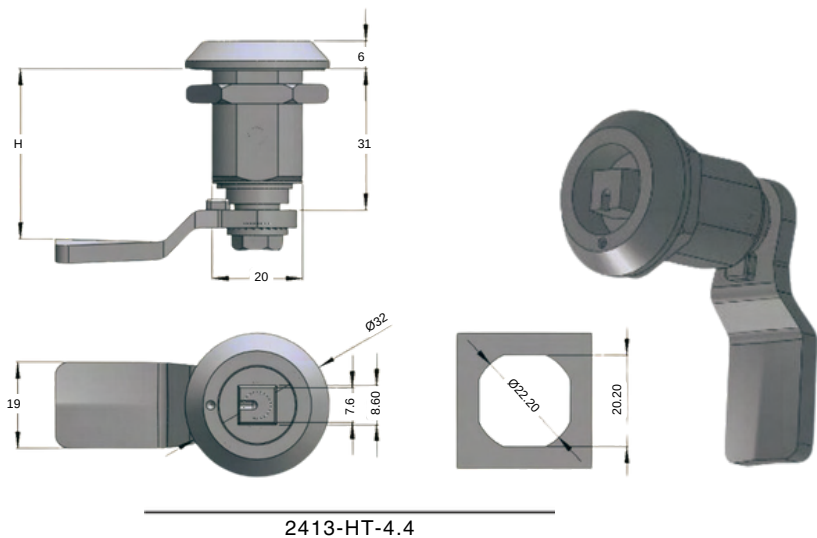

2413-HT-4.4

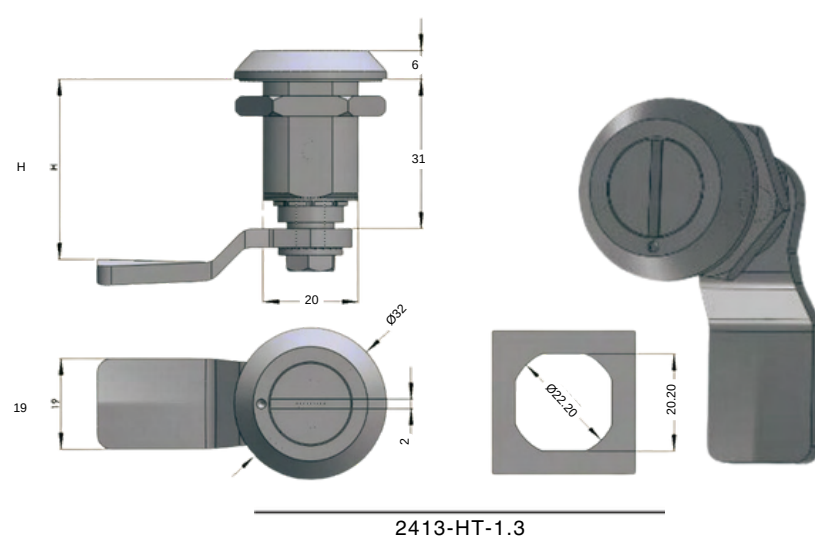

2413-HT-1.3



# COMPRESSION LATCH HT-316

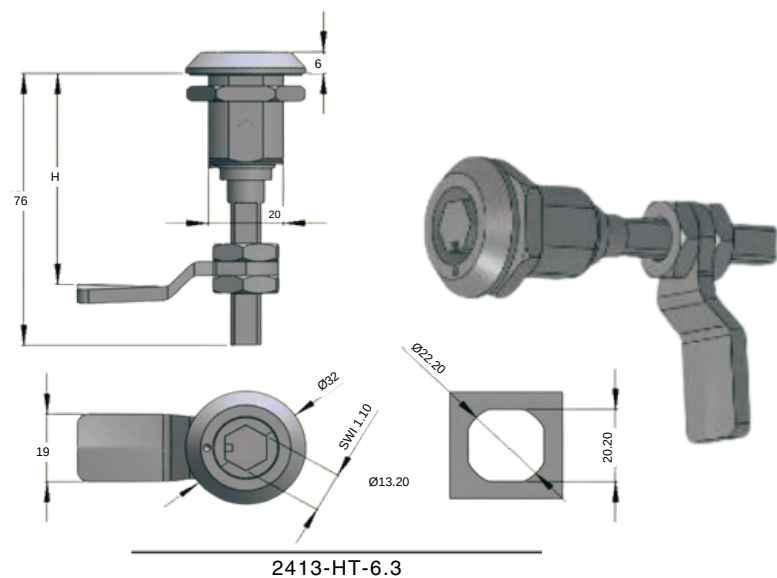
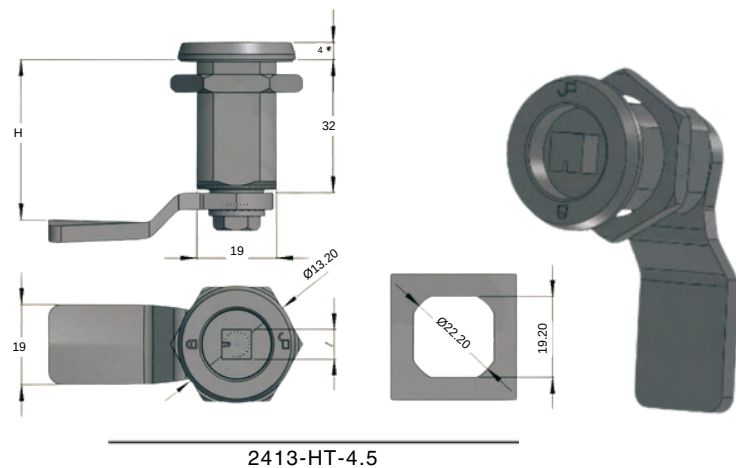

COMPRESSION LATCH





## KEYS

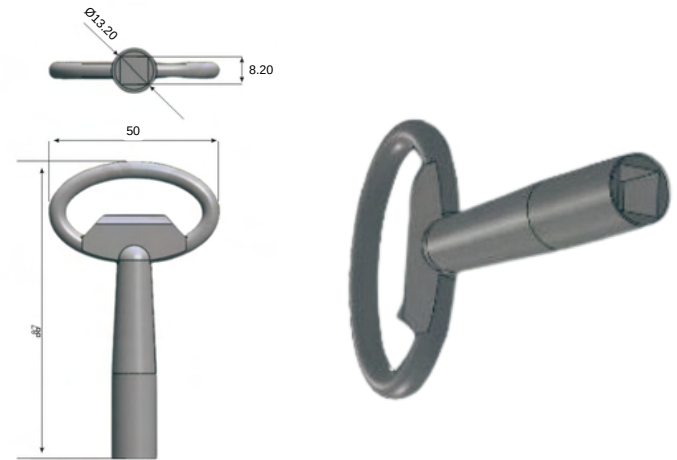

STAINLESS STEEL KEY

1360-HT-4.1

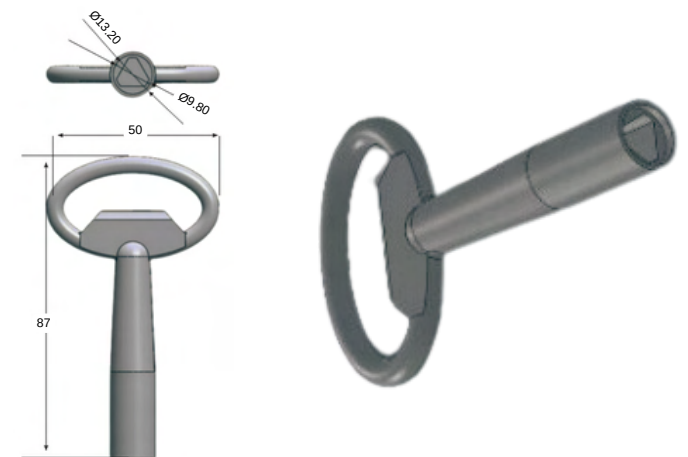

STAINLESS STEEL KEY

1360-HT-3.1

# KEYS HT-316



# KEYS HT-316

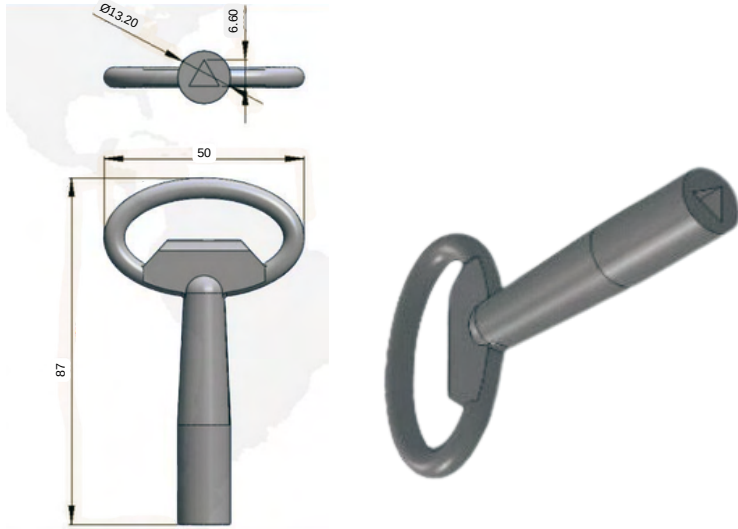

STAINLESS STEEL KEY

1360-HT-3.2



STAINLESS STEEL KEY

1360-HT-2.2

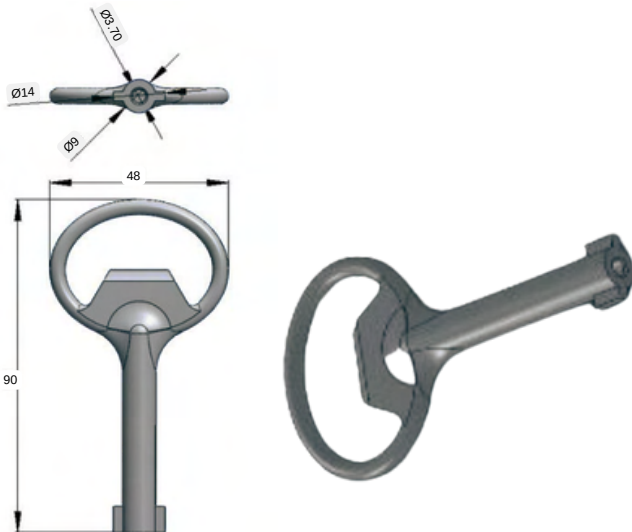

STAINLESS STEEL KEY

1360-HT-2.1

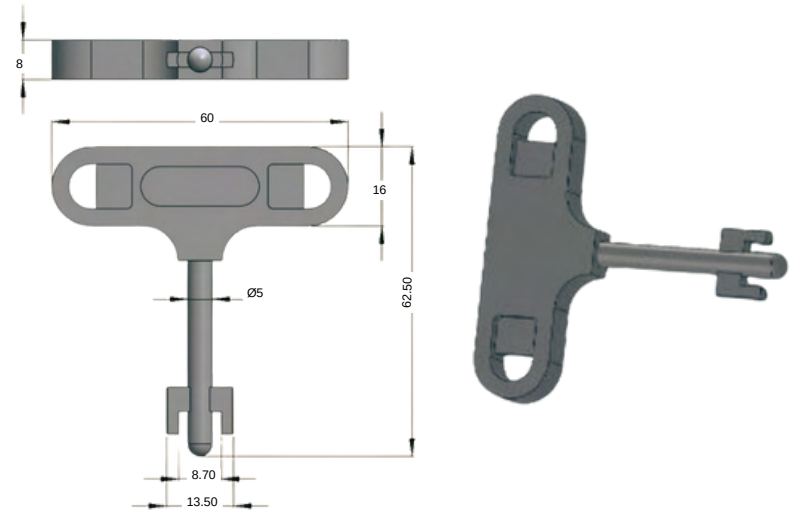

STAINLESS STEEL KEY

1360-HT-1.1

# KEYS

# KEYS HT-316



# KEYS HT-316

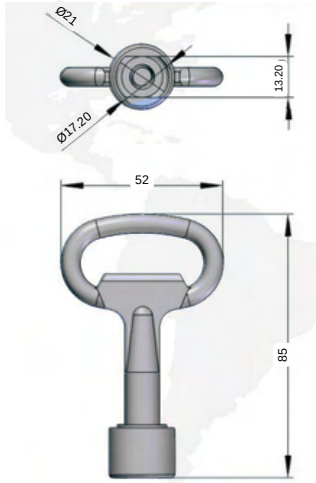

STAINLESS STEEL KEY

1360-HT-2.3

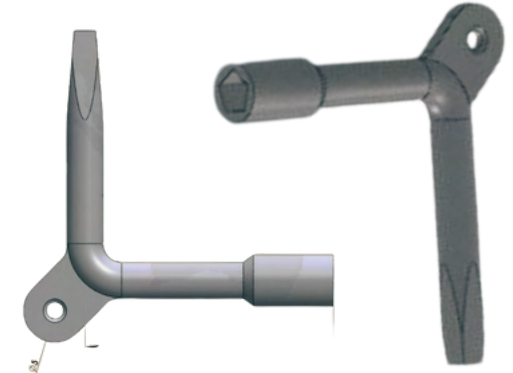
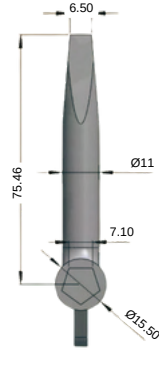

STAINLESS STEEL KEY

1360-HT-5.1

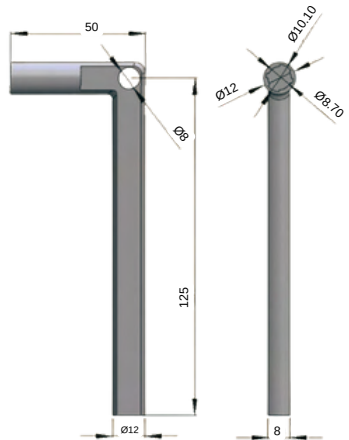

STAINLESS STEEL KEY

1360-HT-1.2

# KEYS

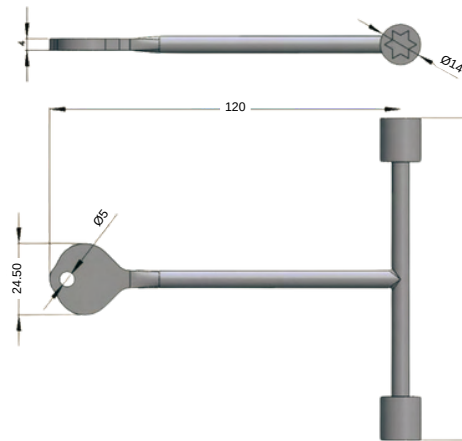

STAINLESS STEEL KEY

1360-HT-6.1

**KEYS HT-316**

**HDT**  
HARDWAREONTIME

**KEYS HT-316**

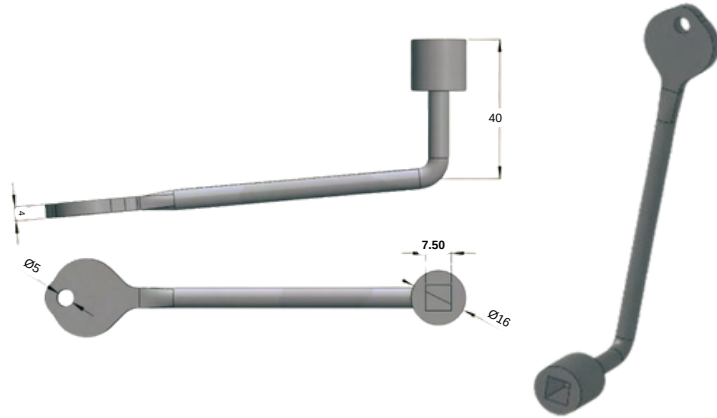

STAINLESS STEEL KEY

1360-HT-1.3

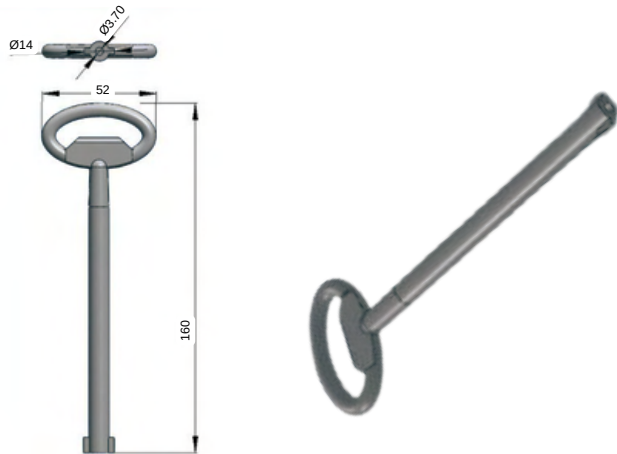

STAINLESS STEEL KEY

1360-HT-12.1

**KEYS**

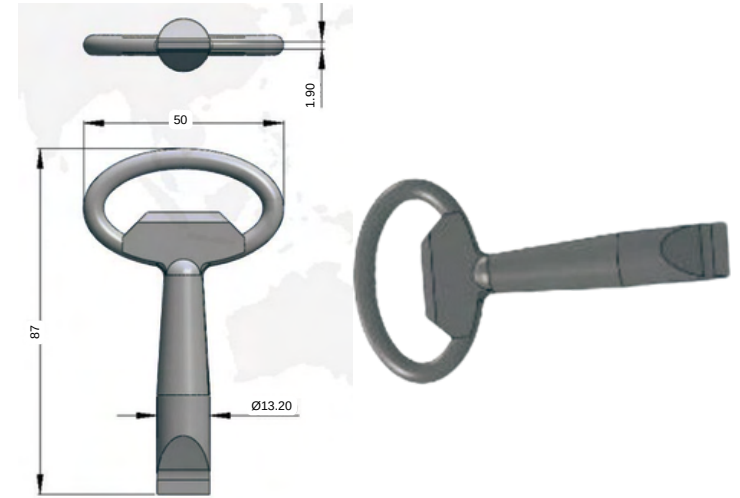

STAINLESS STEEL KEY

1360-HT-1.4

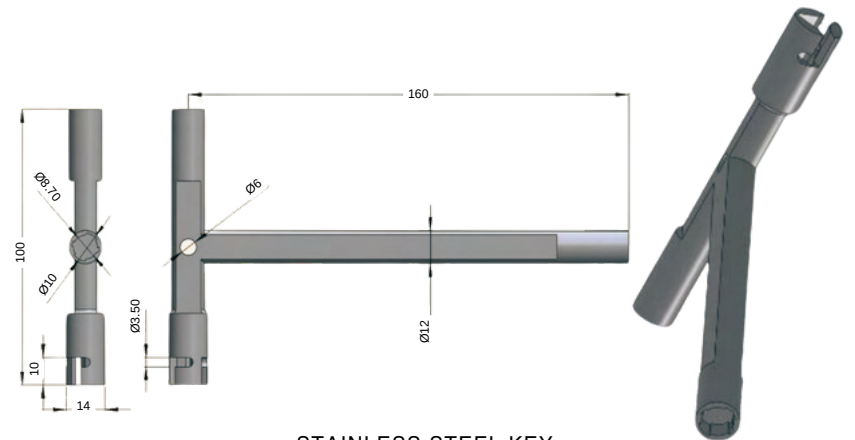

STAINLESS STEEL KEY

1360-HT-1.5

**KEYS HT-316**

**HDT**  
HARDWAREONTIME

**KEYS HT-316**

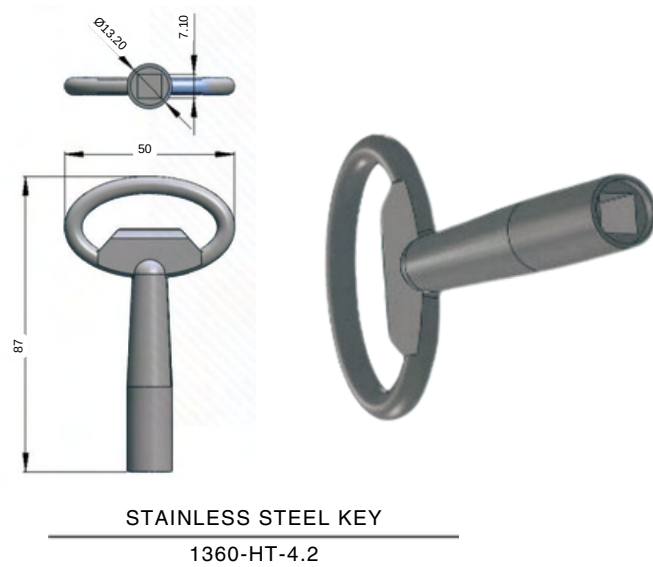
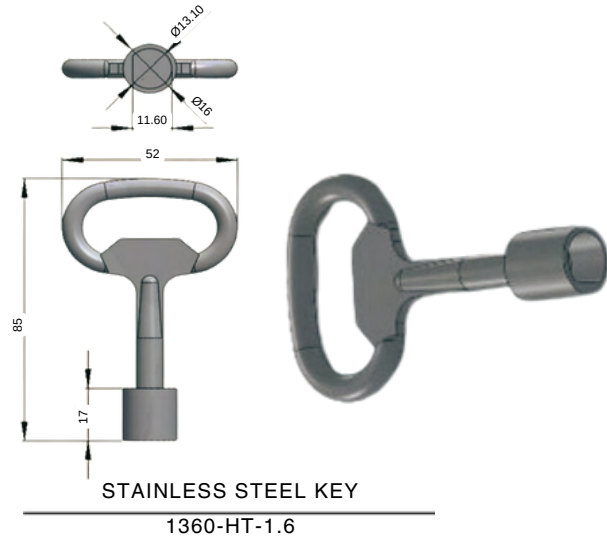

**KEYS**

**HDT**  
HARDWAREONTIME





## FITTINGS

 [www.hardwareontime.com](http://www.hardwareontime.com)

 [Info@hardwareontime.com](mailto:Info@hardwareontime.com)

 +861 5001 790 862

## FITTINGS HT-316

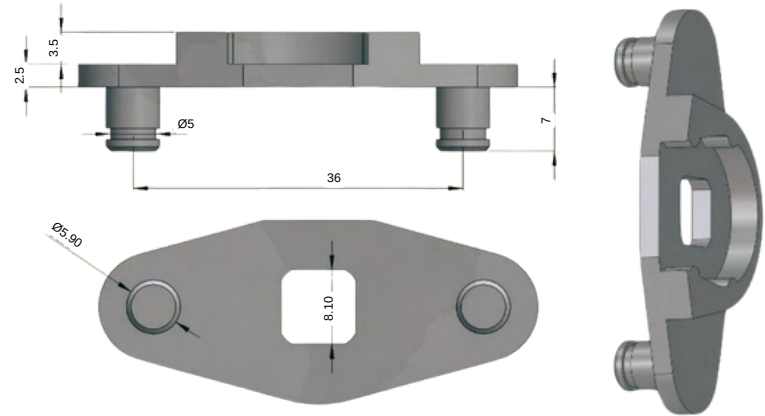

STAINLESS STEEL FITTINGS

1205-HT-1.1

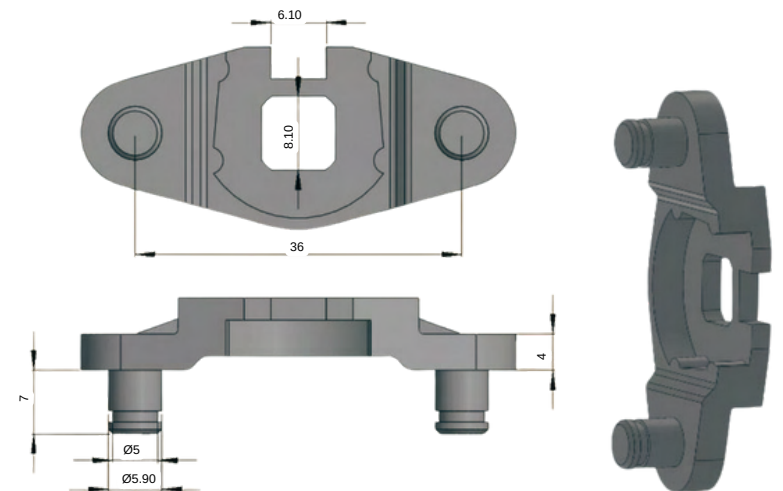

STAINLESS STEEL FITTINGS

1205-HT-1.2

# FITTINGS HT-316



# FITTINGS HT-316

# FITTINGS

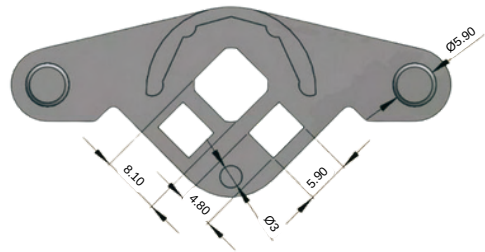
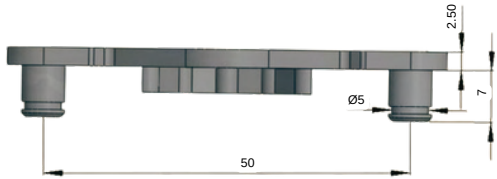

STAINLESS STEEL FITTINGS

1205-HT-1.3

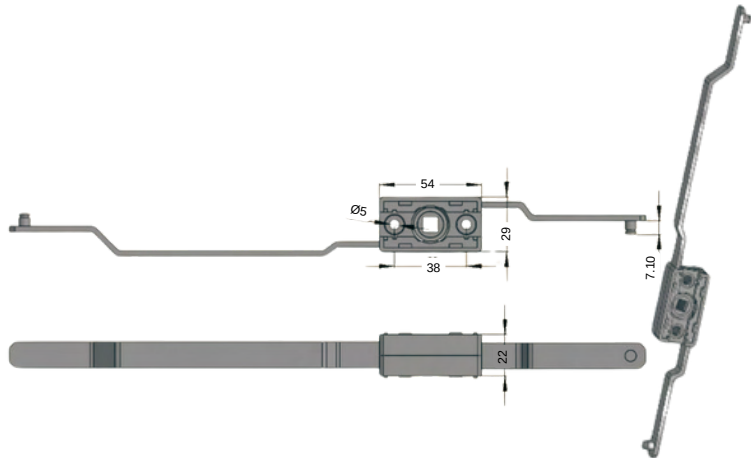

STAINLESS STEEL FITTINGS

1205-HT-1.4

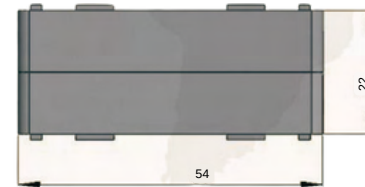
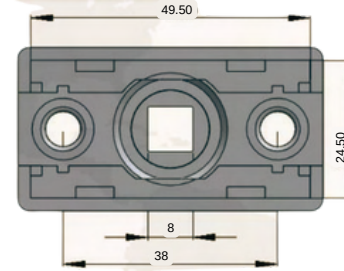

STAINLESS STEEL FITTINGS

1205-HT-1.5

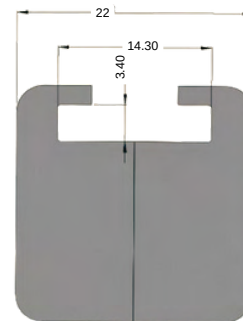
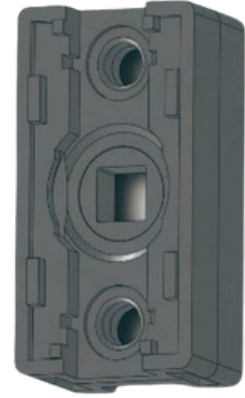

STAINLESS STEEL FITTINGS

1205-HT-1.6

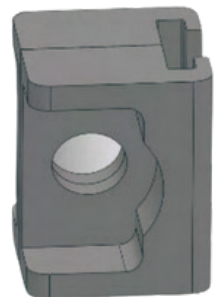
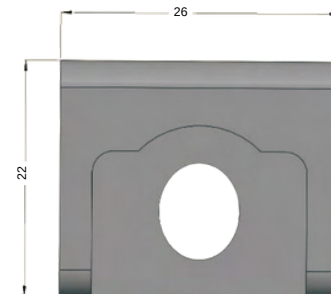

# FITTINGS HT-316

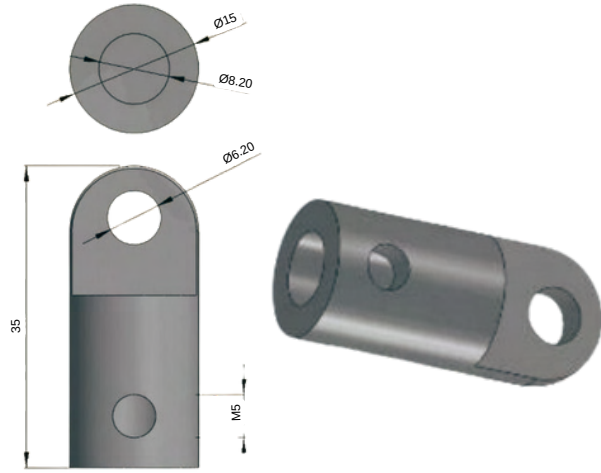

STAINLESS STEEL FITTINGS

1205-HT-1.7

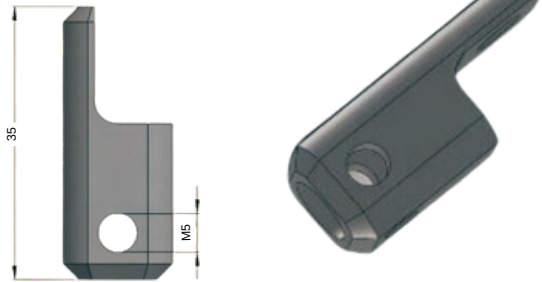
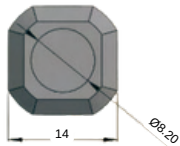

STAINLESS STEEL FITTINGS

1205-HT-1.8

FITTINGS





## CAM

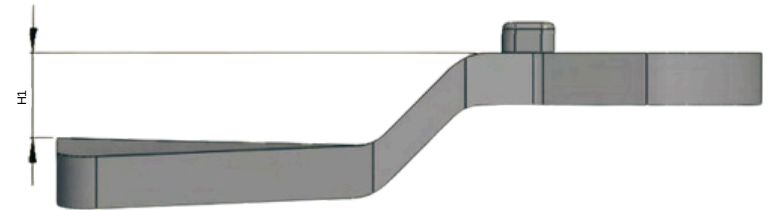
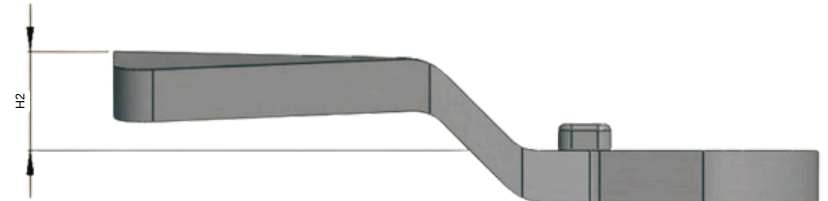

PROGRAM STAINLESS STEEL CAM

	H1	H2
1010-HT-1.1	2	
1010-HT-1.2	4	
1010-HT-1.3	6	
1010-HT-1.4	8	
1010-HT-1.5	10	
1010-HT-1.6	0	0
1010-HT-1.7		4
1010-HT-1.8		8
1010-HT-1.9		12